

# AXIA<sup>®</sup>

STAIR & RAILING SYSTEMS



STYLE



QUALITY



VALUE

AXIA<sup>®</sup>  
STAIR & RAILING SYSTEMS

Full Product Line Catalog Edition 001-A



## style

[stahyl]

**noun**

an elegant, fashionable, or luxurious mode of living: to live in style.

## quality

[kwol-i-tee]

**noun**

high grade; superiority; excellence: railing of exceptional quality

## value

[val-yoo]

**noun**

relative worth, merit, or importance: the value of a home

**Stainless steel**

In metallurgy, stainless steel, also known as inox steel or inox from French inoxydable (inoxidizable), is a steel alloy with a minimum of 10.5% chromium content by mass.

Stainless steel is notable for its corrosion resistance, and it is widely used for food handling and cutlery among many other applications.

Stainless steel does not readily corrode, rust or stain with water as ordinary steel does. However, it is not fully stain-proof in low-oxygen, high-salinity, or poor air-circulation environments.

There are various grades and surface finishes of stainless steel to suit the environment the alloy must endure. Stainless steel is used where both the properties of steel and corrosion resistance are required.

Stainless steel differs from carbon steel by the amount of chromium present. Unprotected carbon steel rusts readily when exposed to air and moisture. This iron oxide film (the rust) is active and accelerates corrosion by making it easier for more iron oxide to form. Since iron oxide has lower density than steel, the film expands and tends to flake and fall away. In comparison, stainless steels contain sufficient chromium to undergo passivation, forming an inert film of chromium oxide on the surface. This layer prevents further corrosion by blocking oxygen diffusion to the steel surface and stops corrosion from spreading into the bulk of the metal. Passivation occurs only if the proportion of chromium is high enough and oxygen is present in it.

Stainless steel’s resistance to corrosion and staining, low maintenance, and familiar lustre make it an ideal material for many applications.

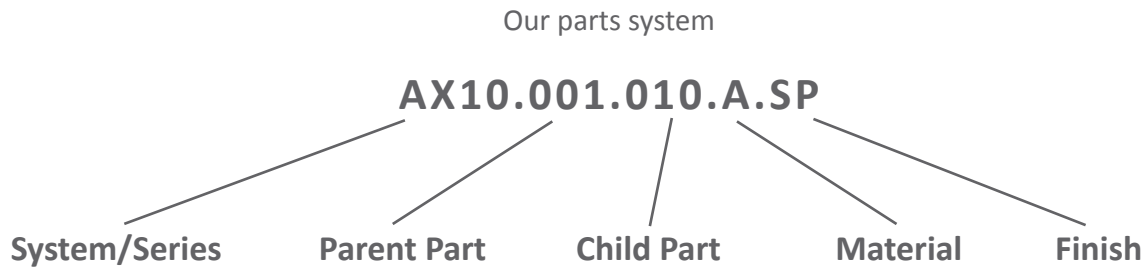

**Parts that require adhesive**

We offer a complete selection of the highest grade adhesives for professional installation.

Page 69



Quick# **260X**  
Page 68

**Parts that require hardware**

Our parts are available with a full range of system hardware as well as anchors for mounting to wood and concrete.

Page 68



Drill Kit **AX00.070.640**  
Page 70

**Installation kits available**

Our complete offering of installation kits, tools and accessories makes it easy to professionally install our systems.

Page 70

# Index

## Post Railing Systems

### ROUND SERIES



### INFILL OPTIONS

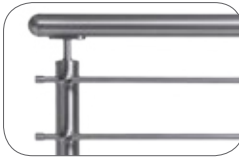

Round Tube Infill 4-7

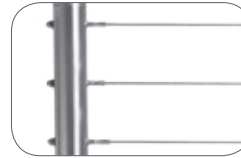

Cable Infill 8-13



Glass Clamps 14-17

### POST OPTIONS

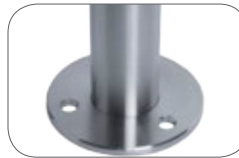

Round Post  
Options 18-21

### HANDRAIL OPTIONS



Round Handrail  
Options 22-25

### SQUARE SERIES



### INFILL OPTIONS



Bar/Tube Infill 26-29



Cable Infill 30-35



Glass Clamps 36-39

### POST OPTIONS

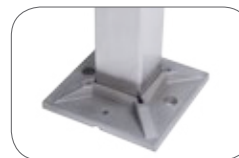

Square Post  
Options 42-43



Wood Post  
Options 42-43

### HANDRAIL OPTIONS



Square Handrail  
Options 42-45



Wood Handrail  
Options 42-45

# Glass Railing Systems

## STANDOFF SERIES



Round Standoffs  
46-49



Square Standoffs  
50-53

## U CHANNEL SERIES



Floor Mount 54-61



Wall Mount 54-61

## CAP RAIL OPTIONS



Round Top rail  
Options 62-65



Square Top rail  
Options 66-67



Wood Top rail  
66-67

## ACCESSORIES



## INSTALLATION



Hardware 68



Adhesives 69



Tools & Accessories  
70-71



Specialty Tools 72



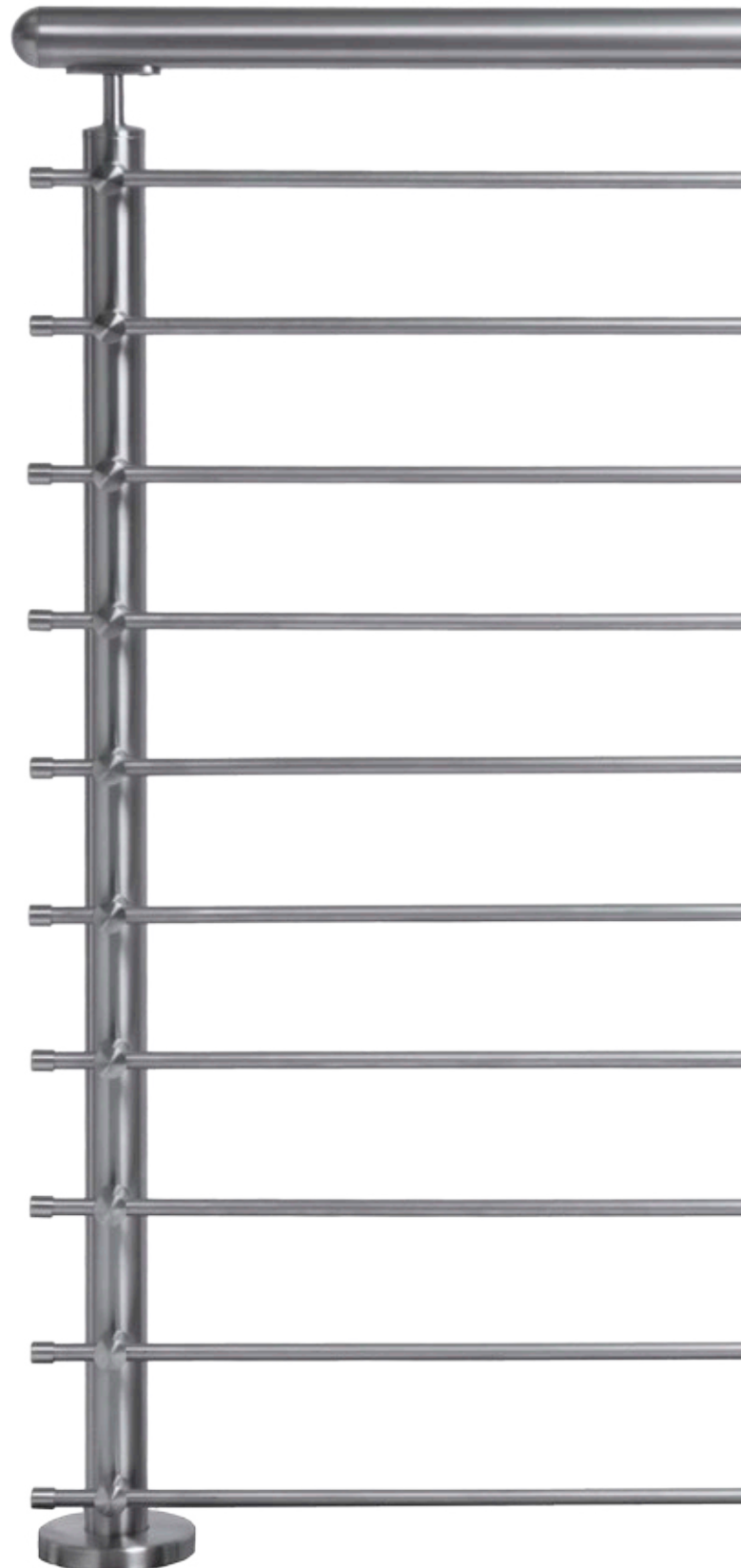

COD.	Ø	L	Wt.
<b>AX10.009.83000.A.SP</b>	12 x 1.5 mm	3000 mm	1.1 kgs (2.42 lbs)
<b>AX10.009.85800.A.SP</b>	12 x 1.5 mm	5800 mm	2.1 kgs (4.64 lbs)



**Round tube infill**



COD.	D	D2	MA
<b>AX10.010.200.A.SP</b>	42.4 mm	12 mm	6.5 mm

**Round tube infill holder**

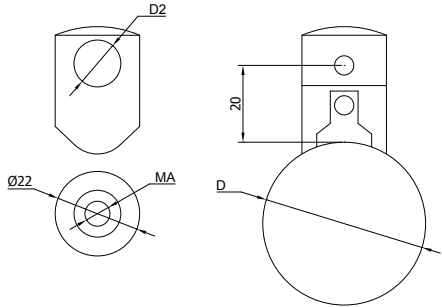
**Weight:**  
.053 kgs (.117 lbs)







**Quick# 260X**  
Page 68

COD.	B	A
<b>AX10.010.206.A.SP</b>	42.4 mm	12 mm

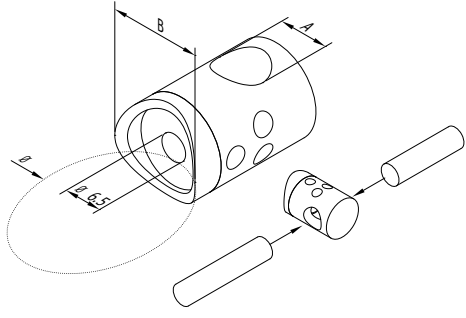
**Round tube infill holder - connector**

**Weight:**  
.054 kgs (.118 lbs)

**Quick# 260X**  
Page 68







COD.	Ø	L
<b>AX10.010.082.A.SP</b>	12 mm	36 mm

**Inline connector**

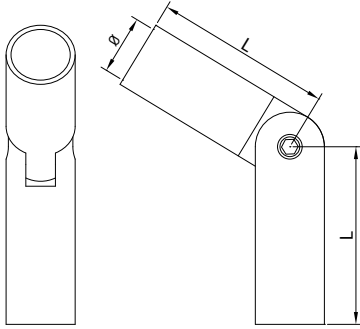

**Weight:**  
.03 kgs (.066 lbs)

COD.	X	D
<b>AX10.010.209.A.SP</b>	flat	12 mm

**Inline holder for flat mount**

**Weight:**  
.126 kgs (.277 lbs)

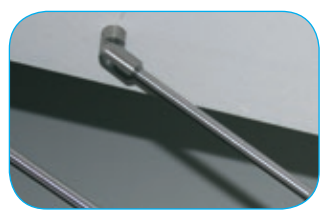
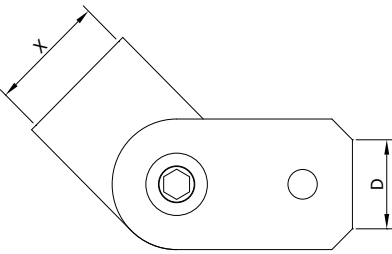





**Quick# 825X**  
Page 68

COD.	D2	D3
<b>AX10.010.208.A.SP</b>	12 mm	12 mm

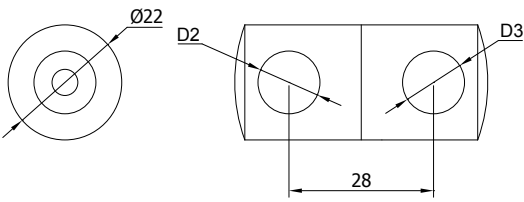
**Cross holder**



**Weight:**  
.098 kgs (.216 lbs)

COD.	D	L
<b>AX10.010.081.A.SP</b>	12 mm	15 mm

**End cap**

**Weight:**  
.011 kgs (.024 lbs)

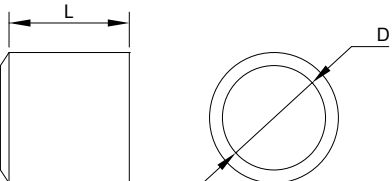



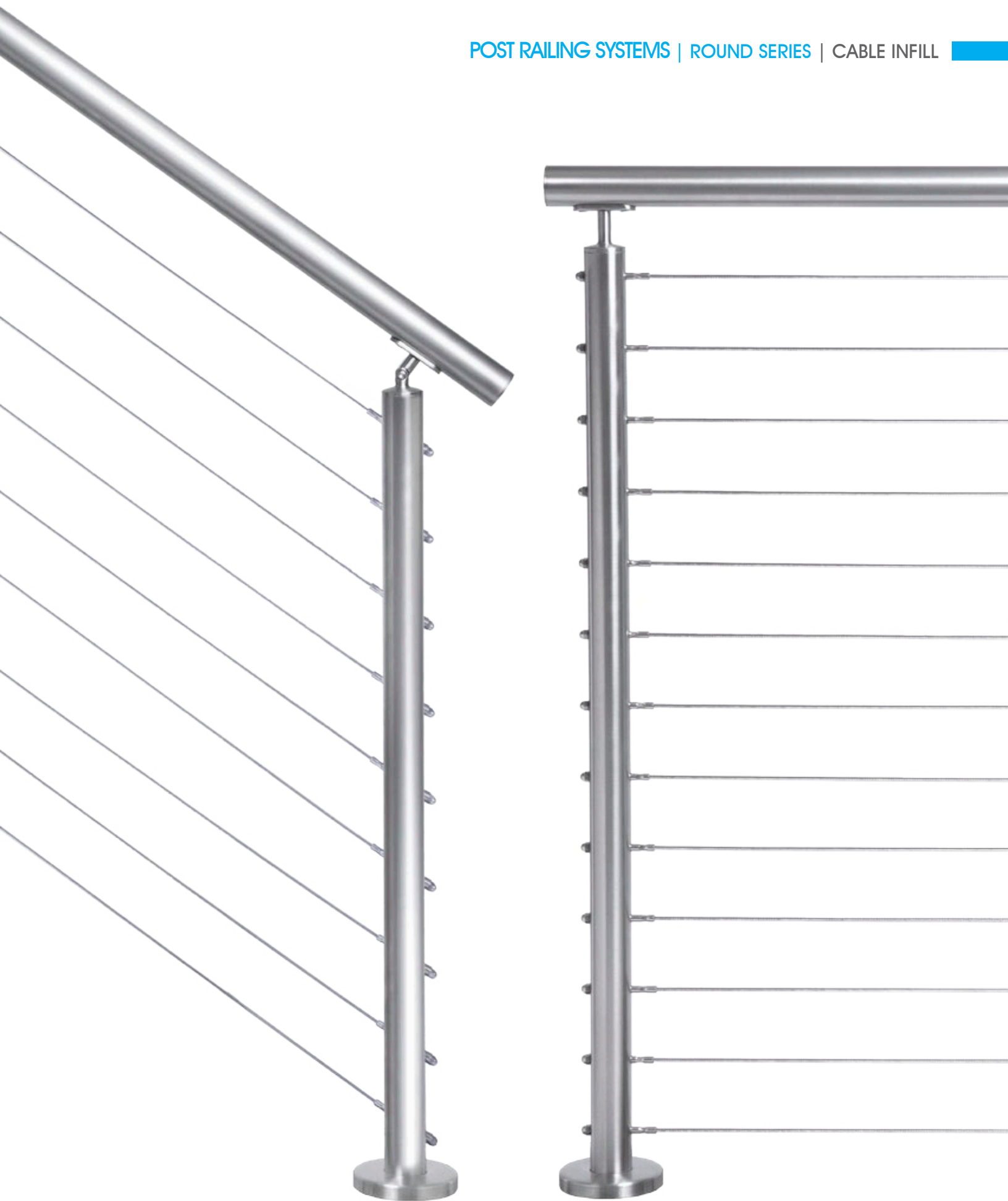

COD.	L	Wt.
<b>HFC18.212-5</b>	5'	.15 kgs (.331 lbs)
<b>HFC18.212-10</b>	10'	.227 kgs (.5 lbs)
<b>HFC18.212-15</b>	15'	.303 kgs (.669 lbs)
<b>HFC18.212-20</b>	20'	.383 kgs (.844 lbs)
<b>HFC18.212-25</b>	25'	.549 kgs (1.2 lbs)

Outside to outside  
Level/balcony or angle/rake  
Steel posts

Drill Kit AX00.070.640  
Page 70



COD.	L	Wt.
<b>HFC18.102-5</b>	5'	.15 kgs (.331 lbs)
<b>HFC18.102-10</b>	10'	.227 kgs (.5 lbs)
<b>HFC18.102-15</b>	15'	.303 kgs (.669 lbs)
<b>HFC18.102-20</b>	20'	.383 kgs (.844 lbs)
<b>HFC18.102-25</b>	25'	.549 kgs (1.2 lbs)

Outside to outside  
Level/balcony or angle/rake  
Steel or wood posts

Drill Kit AX00.070.630  
Page 70



COD.	L	Wt.
<b>HFC18.401-5</b>	5'	.15 kgs (.331 lbs)
<b>HFC18.401-10</b>	10'	.227 kgs (.5 lbs)
<b>HFC18.401-15</b>	15'	.303 kgs (.669 lbs)
<b>HFC18.401-20</b>	20'	.383 kgs (.844 lbs)
<b>HFC18.401-25</b>	25'	.549 kgs (1.2 lbs)

Inside to inside  
Level/balcony

Drill Kit AX00.070.645  
Page 70



COD.	L	Wt.
<b>HFC18.500M-5</b>	5'	.15 kgs (.331 lbs)
<b>HFC18.500M-10</b>	10'	.227 kgs (.5 lbs)
<b>HFC18.500M-15</b>	15'	.303 kgs (.669 lbs)
<b>HFC18.500M-20</b>	20'	.383 kgs (.844 lbs)
<b>HFC18.500M-25</b>	25'	.549 kgs (1.2 lbs)

Inside to inside  
Level/balcony or angle/rake

Drill Kit AX00.070.650  
Page 70

AISI 316



1 x 19 Cable - 1/8" Diameter



AISI 316



Available in 328' spool

COD.	Dim. mm	Length	kg/100 m
AX00.040.215.B.M	4 mm	100 m	6.14

1x19 Cable - Bulk

Weight:  
8.5 kgs (18.73 lbs)

COD.	G	mm	L1	L2	L3	D	A	kg/100
AX00.050.220DX.B.SP	M6	4	88	30	50	7	4.5	1.2

Right handed cable terminal stud (DX)

Weight:  
.016 kgs (.035 lbs)

AISI 316

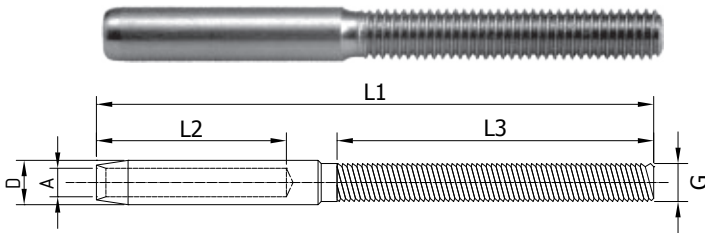

Hydraulic crimper



Page 72

Drill Kit AX00.070.610  
Page 70

COD.	G	mm	L1	L2	L3	D	A	kg/100
AX00.050.221SX.B.SP	M6	4	88	30	50	7	4.5	1.2

Left handed cable terminal stud (SX)

Weight:  
.016 kgs (.035 lbs)

AISI 316

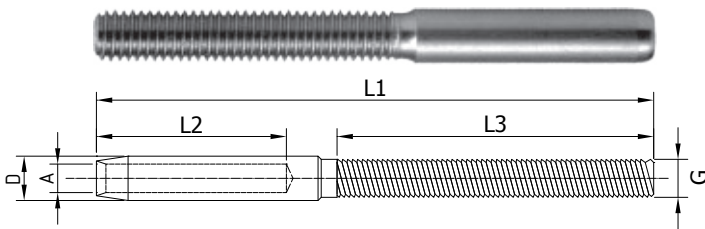

Hydraulic crimper



Page 72

Drill Kit AX00.070.610  
Page 70

AISI 316

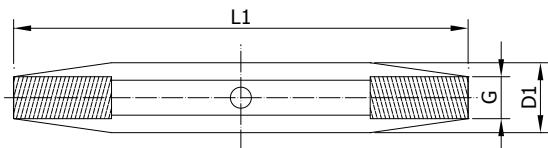

COD.	G	L1	D1	kg/100
AX00.050.235.B.SP	M6	65	10	1.7

Middle-tensioning body

Weight:  
.025 kgs (.055 lbs)



COD.	NV	G	kg/100
<b>AX00.050.231SX.B.SP</b>	10	M6	0.9 LEFT
<b>AX00.050.230DX.B.SP</b>	10	M6	0.9 RIGHT

AISI 316

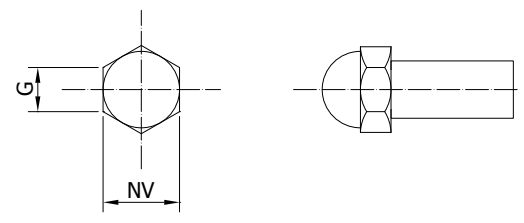

### Threaded nut caps tensioner

**Weight:**  
.006 kgs (.013 lbs)

Drill Kit **AX00.070.610**  
Page 70



AISI 316

COD.	d	Ø	e
<b>AX10.060.240.B.SP</b>	10 mm	42.4 mm	12 mm ROUND

### Sloping washer for round posts

**Weight:**  
.006 kgs (.013 lbs)

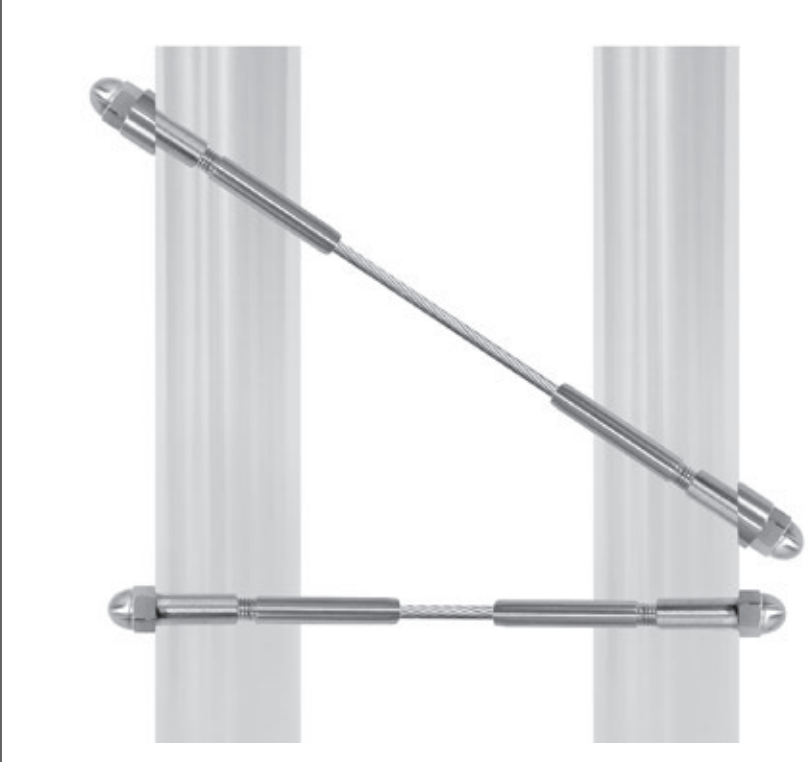
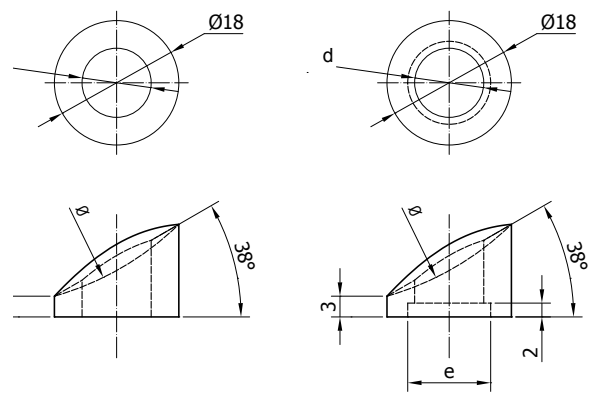







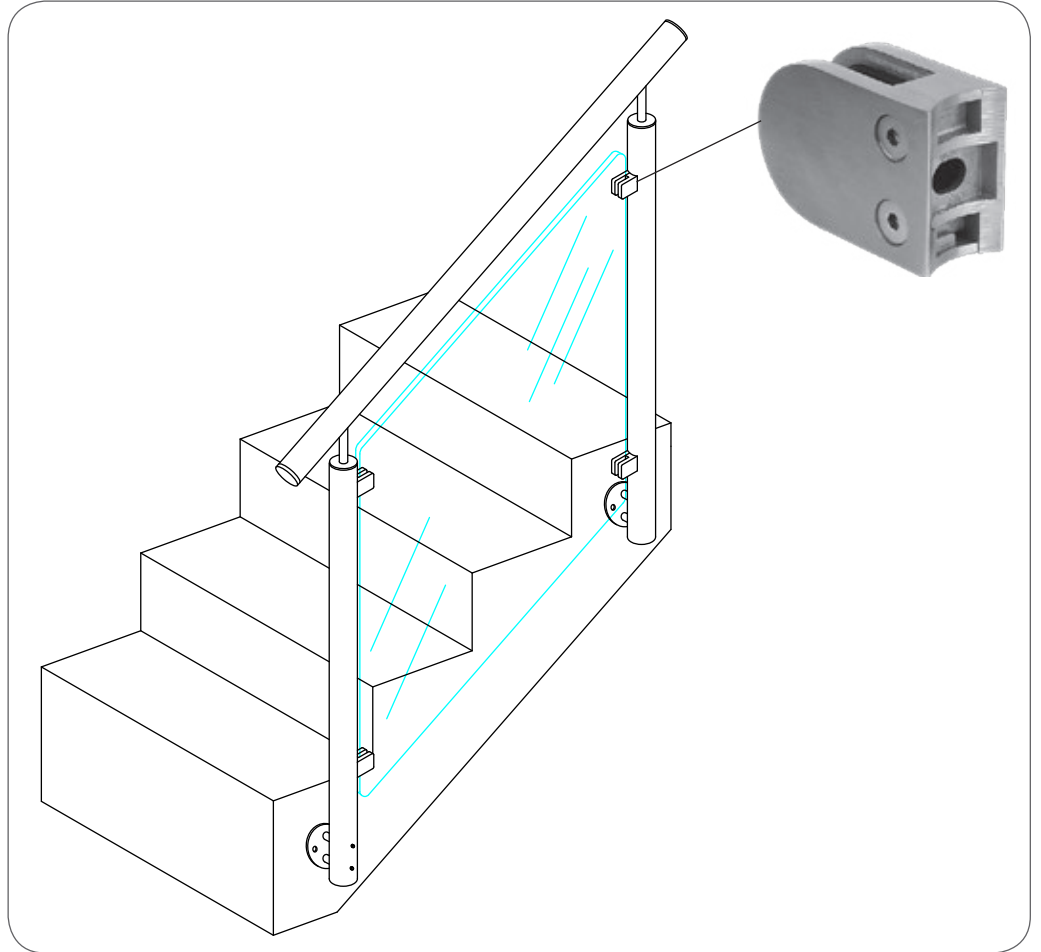
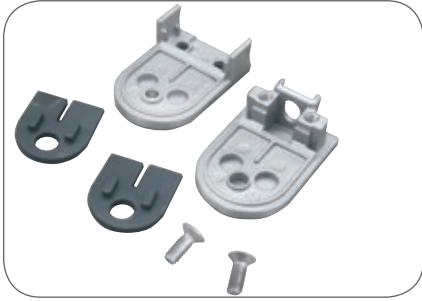

COD.	Ø	L
------	---	---

**AX10.014.180.A.SP** 42.4 mm 10 - 12.76 mm

### Glass clamps for round posts

**Weight:**  
.303 kgs (.667 lbs)

Rubber inserts not included  
Available for 3/8" & 1/2" monolithic glass

Quick# 255X  
Page 68

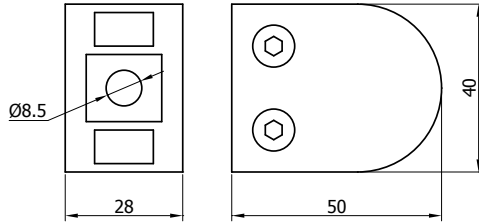
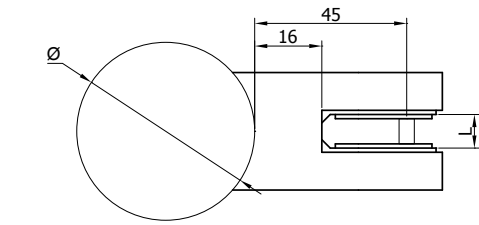

Swift plate and safety pin included

COD.	T
------	---

**AX10.015.182R** 10 mm for 3/8" glass

**AX10.015.183R** 12 mm for 1/2" glass

### Glass clamp inserts

**Weight:**  
.009 kgs (.02 lbs)

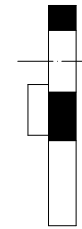
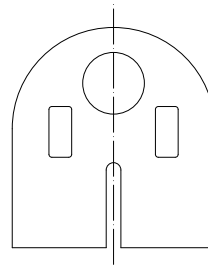

sold in pairs



COD.	Size
------	------

**AX00.090.266.A.SP** M5  
**AX00.090.267.A.SP** M6  
**AX00.090.269.A.SP** M8

### Pop rivets - threaded inserts

**Weight:**  
.045 kgs (.10 lbs)  
.068 kgs (.15 lbs)  
.113 kgs (.25 lbs)

Provides stronger connection of glass clamps to posts than standard tap/screw

Quick# 255X, 260X  
Page 68

Sold in packages of 25



Pop rivet tool

Page 72

COD.	Ø	ØBase	Height
<b>AX10.001.001.A.SP</b>	42.4 mm	101 mm	1000 mm

**Round post - floor mounted**

**Weight:**  
2.34 kgs (5.15 lbs)

Flange cover included

Quick# 800X  
Page 68

COD.	Ø	D
<b>AX10.008.142.A.SP</b>	105 mm	42.75 mm

**Replacement Flange cover - floor mounted**

**Weight:**  
.086 kgs (.189 lbs)

COD.	Ø
<b>AX10.001.003.D.M</b>	42.4 mm

**Core mount**

**Weight:**  
.849 kgs (1.87 lbs)

COD.	Ø	D
<b>AX10.008.143.A.SP</b>	105 mm	42.75 x 60 mm

**Angled flange cover - core mount**

**Weight:**  
.117 kgs (.257 lbs)

up to 40 degrees

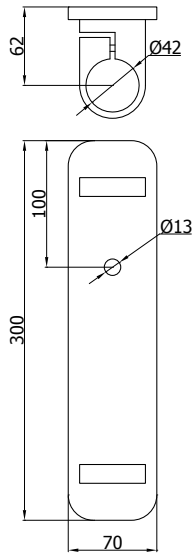

COD.	Ø
AX10.001.002.A.SP	42.4 mm

**Wall mount**

**Weight:**  
.394 kgs (.869 lbs)

Quick#870X  
Page 68

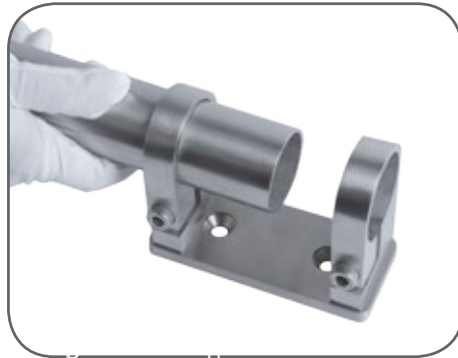

AX10.007.120.A.SP

AX10.007.121.A.SP

Note: End caps should be used on the bottom of the posts.



See page 22





COD.	Ø	D
<b>AX10.005.020.A.SP</b>	42.4 x 2 mm	42.4 mm

**Post handrail support**

**Weight:**  
.174 kgs (.383 lbs)

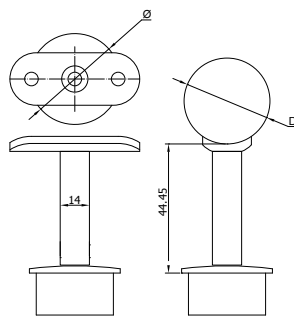
Quick# 250X, 540X  
Page 68







COD.	Ø	D
<b>AX10.005.021.A.SP</b>	42.4 x 2 mm	42.4 mm

**Post handrail support - adjustable**

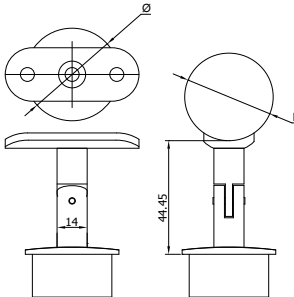
**Weight:**  
.164 kgs (.361 lbs)

Quick# 250X, 540X  
Page 68









COD.	Ø	D
<b>AX10.005.026.A.SP</b>	42.4 x 2 mm	42.4 mm

**Rail support - beveled/coped**

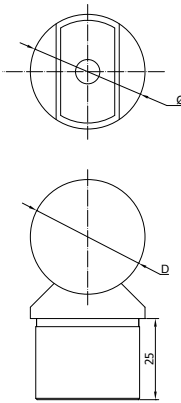
**Weight:**  
.118 kgs (.26 lbs)

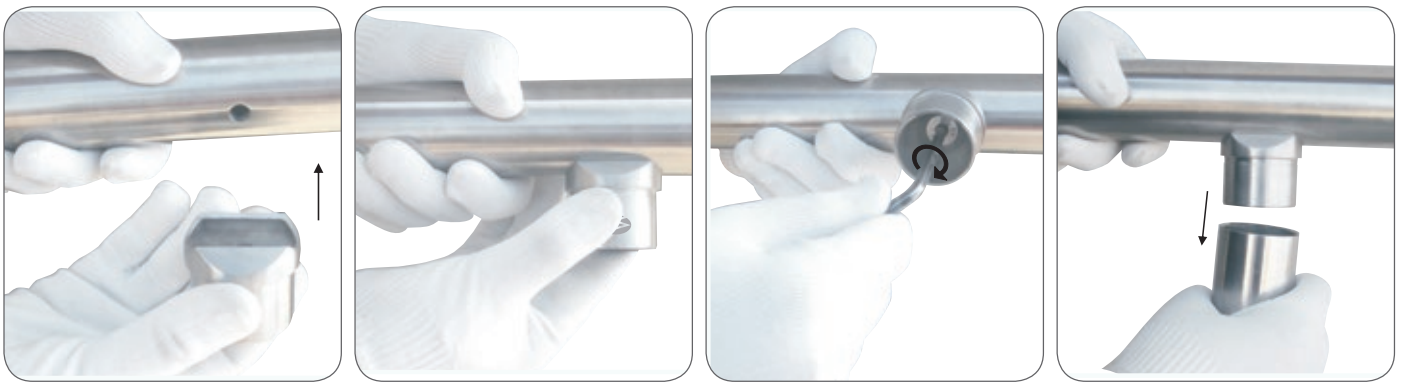
Quick# 260X  
Page 68







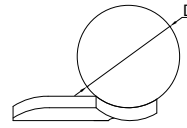
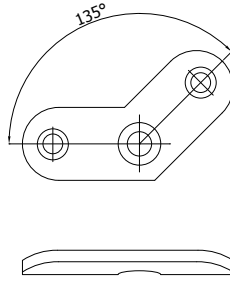
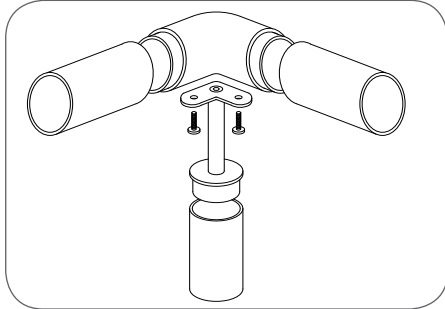

COD. D

**AX10.005.022.A.SP** 42.4 mm

### 45 degree saddle

**Weight:**  
.047 kgs (.103 lbs)



Quick# 250X, 540X  
Page 68

COD. D

**AX10.005.023.A.SP** 42.4 mm

### 90 degree saddle

**Weight:**  
.036 kgs (.079 lbs)

Quick# 250X, 540X  
Page 68

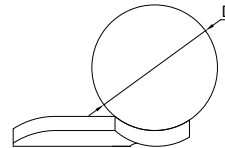
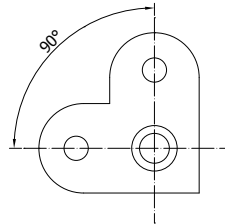

COD. D

**AX10.005.024.A.SP** 42.4 mm

### Saddle - 180 degree - round

**Weight:**  
.037 kgs (.081 lbs)

Quick# 250X, 540X  
Page 68

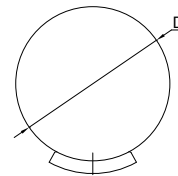
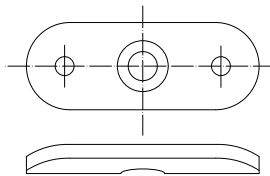



COD.	Ø	L
AX10.004.063.3000.A.SP	42.4 x 2 mm	3000 mm
AX10.004.065.5800.A.SP	42.4 x 2 mm	5800 mm

Round tube handrail

**Weight:**  
6.2 kgs (13.64 lbs)  
11.9 kgs (26.18 lbs)

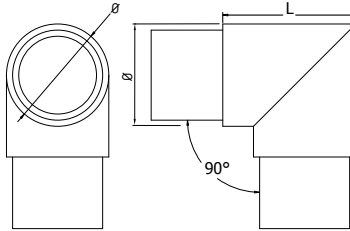

COD.	Ø	L
AX10.008.100.A.SP	42.4 x 2 mm	50 mm

90 degree elbow

**Weight:**  
.266 kgs (.585 lbs)

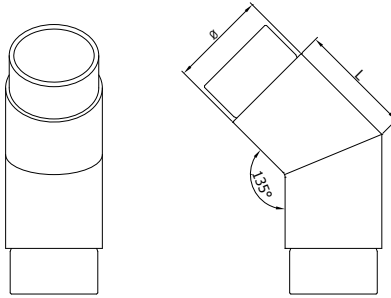

COD.	Ø	L
AX10.008.101.A.SP	42.4 x 2 mm	50 mm

45 degree elbow

**Weight:**  
.316 kgs (.695 lbs)



adjustable

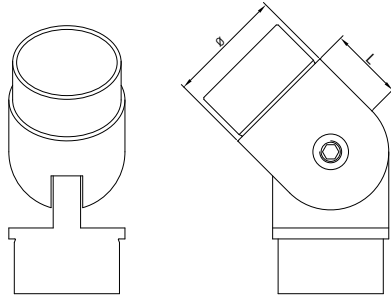

COD.	Ø	L
AX10.008.102.A.SP	42.4 x 2 mm	50 mm

Adjustable ± 90 degree elbow

**Weight:**  
.379 kgs (.834 lbs)

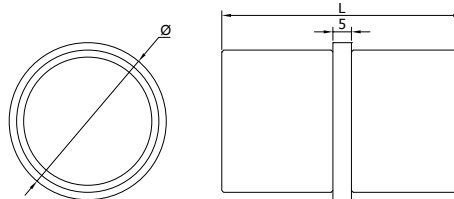

COD.	Ø	L
AX10.008.103.A.SP	42.4 x 2 mm	50 mm

Connector

**Weight:**  
.121 kgs (.166 lbs)

COD.	Ø
AX10.007.120.A.SP	42.4 x 2 mm

Flat end cap

**Weight:**  
.057 kgs (.125 lbs)

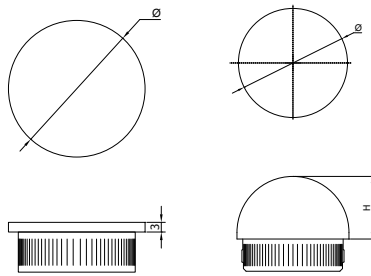

COD.	Ø	H
AX10.007.121.A.SP	42.4 x 2 mm	21 mm

Round end cap

**Weight:**  
.072 kgs (.158 lbs)





COD.	Ø	D
<b>AX10.008.140.A.SP</b>	80 mm	42.4 mm
<b>Wall mount flange</b>		
<b>Weight:</b> .202 kgs (.444 lbs)		
	Flange cover included	
		Quick# 845X Page 68

COD.	Ø	D
<b>AX10.008.139.A.SP</b>	89.7 mm	42.4 mm
<b>Replacement Flange cover</b>		
<b>Weight:</b> .099 kgs (.219 lbs)		

COD.	Ø	
<b>AX10.008.141.A.SP</b>	42.4 x 2 mm	
<b>Adjustable wall mount flange</b>		
<b>Weight:</b> .1 kgs (.22 lbs)		
	Flange cover included	
		Quick# 830X Page 68

  

COD.	Ø	D
<b>AX10.008.142.A.SP</b>	84.6 mm	42.4 mm
<b>Replacement Flange cover</b>		
<b>Weight:</b> .054 kgs (.119 lbs)		

COD.	Ø	L
<b>AX10.033.104.A.SP</b>	42.4 x 2 mm	54 mm
<b>Wall rail return flange</b>		
<b>Weight:</b> .533 kgs (1.17 lbs)		
	Flange cover included	
		Quick# 850X Page 68

COD.	Ø	D
<b>AX10.033.105.A.SP</b>	85.8 mm	42.4 mm
<b>Replacement Flange cover</b>		
<b>Weight:</b> .097 kgs (.213 lbs)		

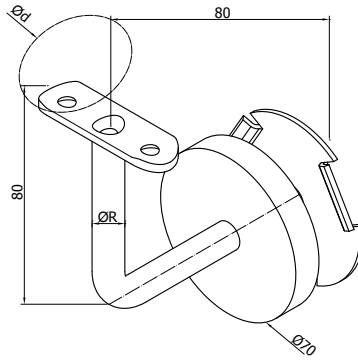

COD.	Ø	R	Ød
AX10.033.023.A.SP	70 mm	12 mm	42.4 mm

### Wall handrail support

Flat saddle sold separately for flat rail options

**Weight:**  
.275 kgs (.605 lbs)

 Quick# 250X, 540X, 855X  
Page 68





for round post

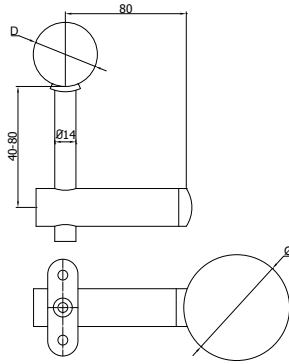

COD.	Ø	Ød
<b>AX10.033.025.A.SP</b>	42.4 mm	42.4 mm

### Post handrail support

Flat saddle sold separately for flat rail options

**Weight:**  
.457 kgs (1.01 lbs)

Quick# 250X, 540X, 260X  
Page 68

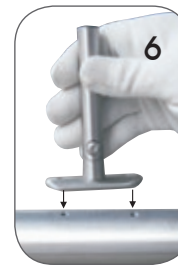
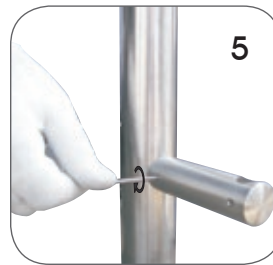
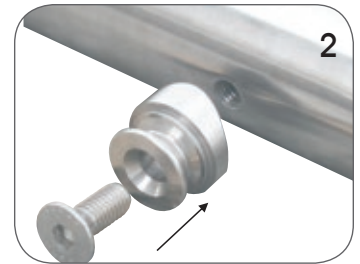
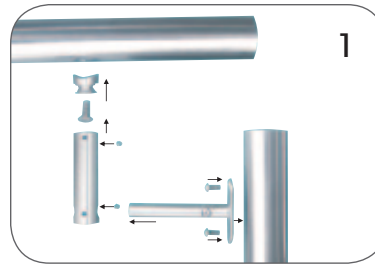
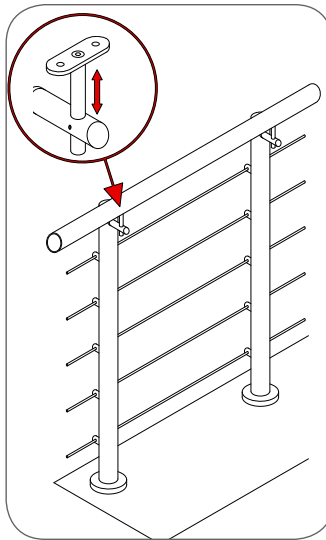
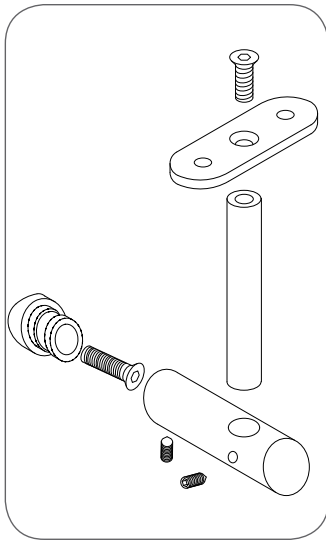

for glass

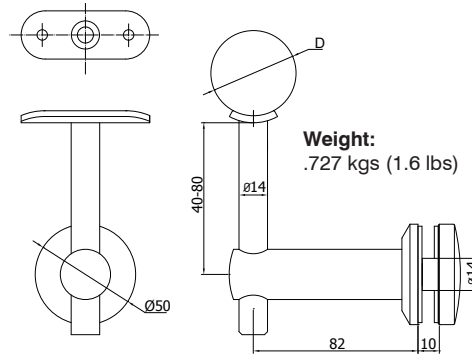

**Weight:**  
.727 kgs (1.6 lbs)

COD.	Ød
<b>AX10.033.024.A.SP</b>	42.4 mm

### Glass handrail support

Flat saddle sold separately for flat rail options

Quick# 250X, 540X  
Page 68

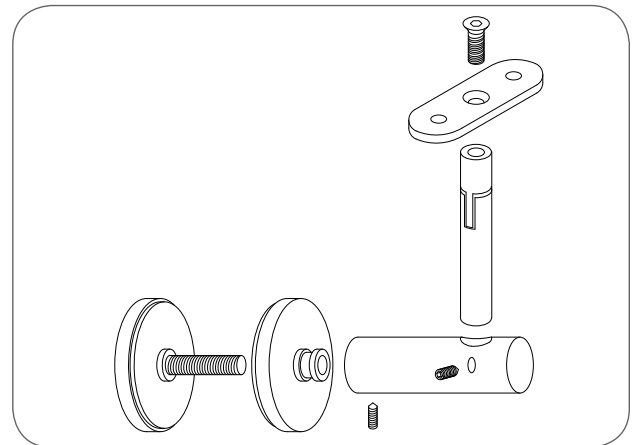
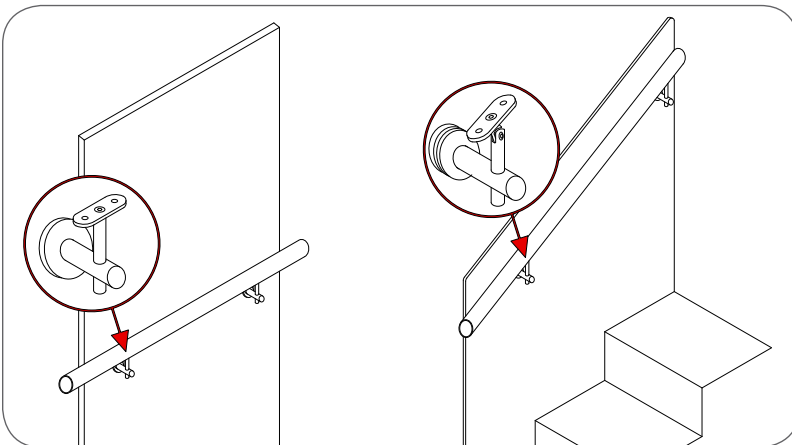



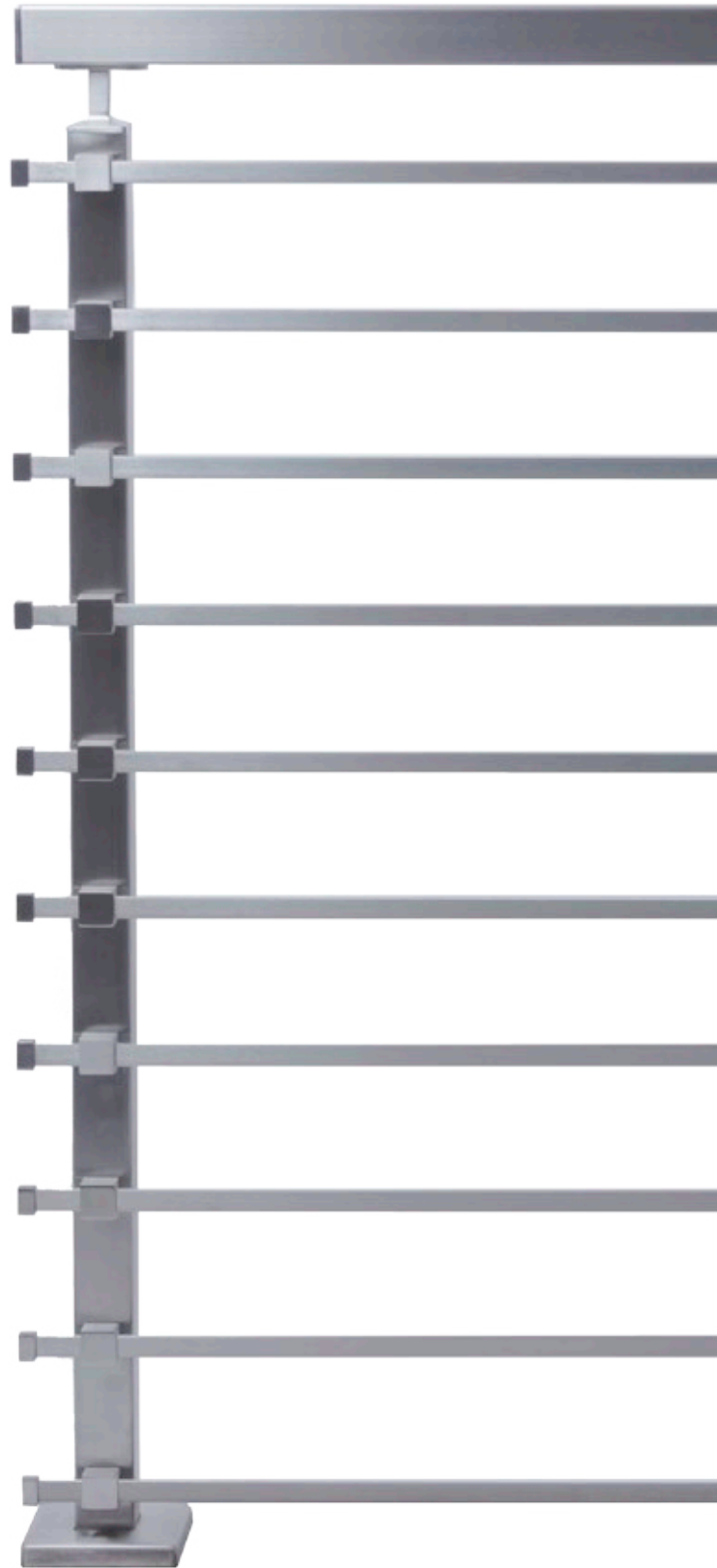

COD.	Ø	L
<b>AX20.009.090.A.SP</b>	15 x 5 mm	5800 mm

**Flat bar infill**

**Weight:**  
3.02 kgs (6.64 lbs)



COD.	X	D
<b>AX20.010.093.A.SP</b>	flat	15 x 5 mm

**Bar holder**

**Weight:**  
.095 kgs (.209 lbs)

Quick# 260X  
Page 68

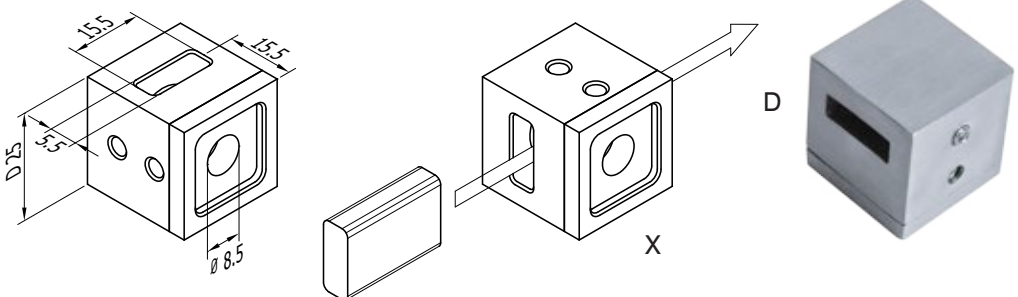

COD.	D
<b>AX20.010.091.A.SP</b>	15 x 5 mm

**Adjustable connector**

**Weight:**  
.134 kgs (.294 lbs)

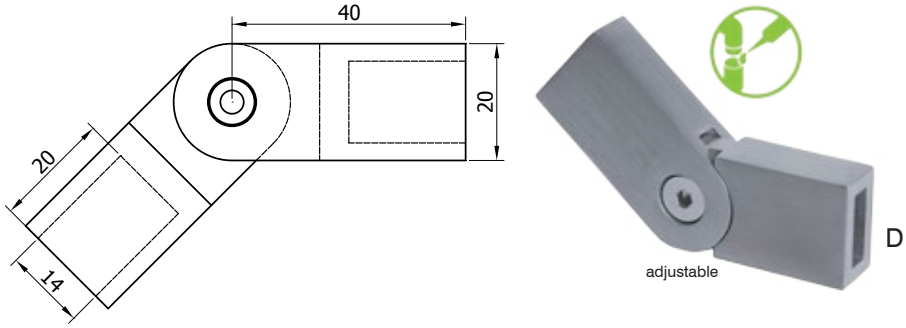

COD.	D
<b>AX20.010.092.A.SP</b>	15 x 5 mm

**End cap**

**Weight:**  
.014 kgs (.031 lbs)

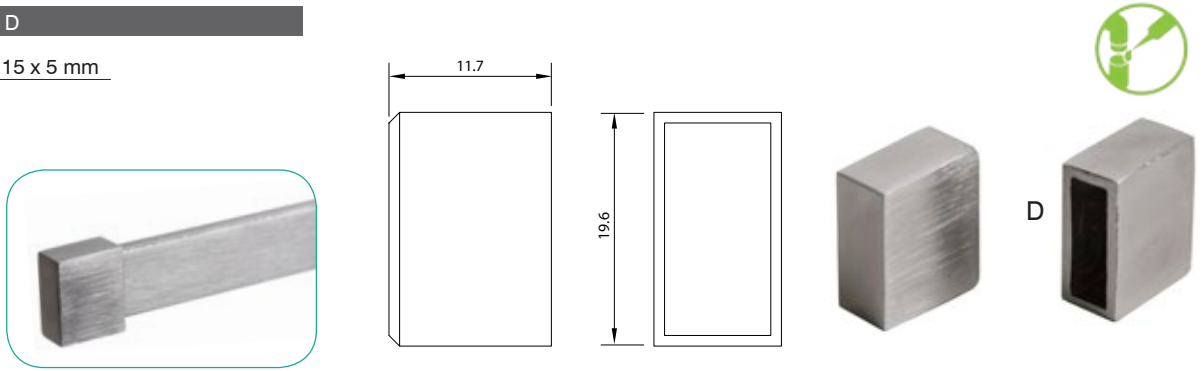

COD.	Ø	L
<b>AX10.009.83000.A.SP</b>	12.0 x 1.5 mm	3000 mm
<b>AX10.009.85800.A.SP</b>	12.0 x 1.5 mm	5800 mm

**Round tube infill**

**Weight:**  
 1.1 kgs (2.42 lbs)  
 2.11 kgs (4.64 lbs)



COD.	D	D2	MA
<b>AX10.010.205.A.SP</b>	flat	12 mm	6.5 mm

**Round tube holder - flat**

**Weight:**  
 .053 kgs (.117 lbs)



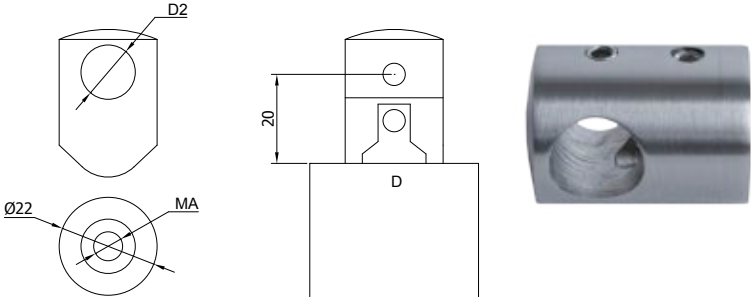

COD.	Ø	L
<b>AX10.010.082.A.SP</b>	hole 12 mm	30 mm

**Adjustable round tube connector**

**Weight:**  
 .03 kgs (.066 lbs)

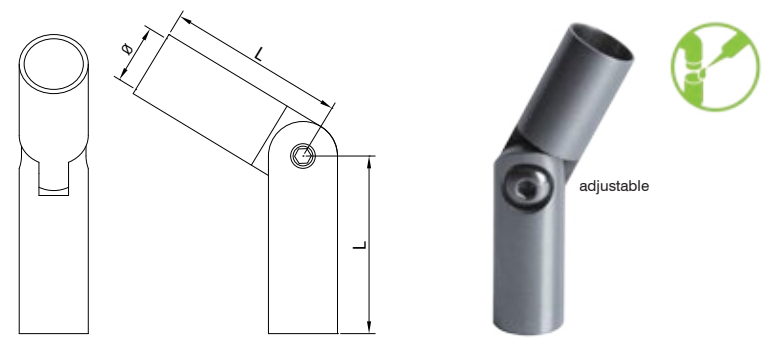

COD.	D	L
<b>AX10.010.081.A.SP</b>	12 mm	15 mm

**Round tube end cap**

**Weight:**  
 .011 kgs (.025 lbs)

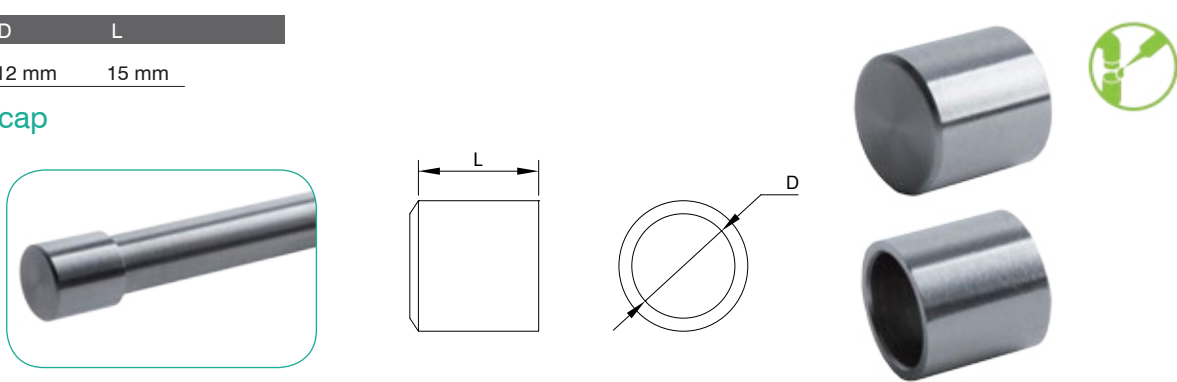





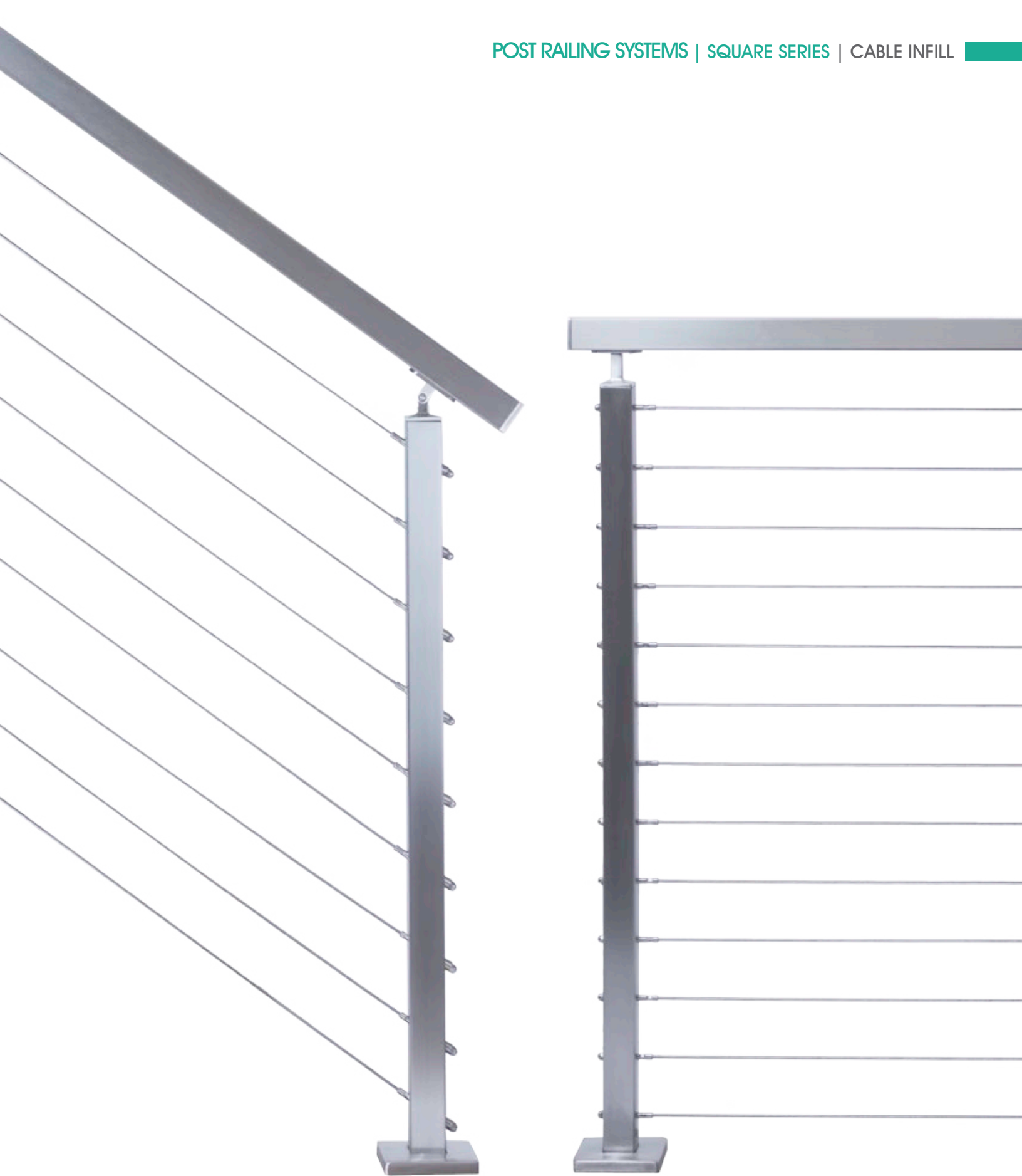

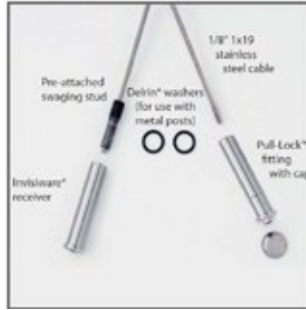

COD.	L	Wt.
<b>HFC18.212-5</b>	5'	.15 kgs (.331 lbs)
<b>HFC18.212-10</b>	10'	.227 kgs (.5 lbs)
<b>HFC18.212-15</b>	15'	.303 kgs (.669 lbs)
<b>HFC18.212-20</b>	20'	.383 kgs (.844 lbs)
<b>HFC18.212-25</b>	25'	.549 kgs (1.2 lbs)

Outside to outside  
Level/balcony or angle/rake  
Steel posts

Drill Kit AX00.070.640  
Page 70



COD.	L	Wt.
<b>HFC18.102-5</b>	5'	.15 kgs (.331 lbs)
<b>HFC18.102-10</b>	10'	.227 kgs (.5 lbs)
<b>HFC18.102-15</b>	15'	.303 kgs (.669 lbs)
<b>HFC18.102-20</b>	20'	.383 kgs (.844 lbs)
<b>HFC18.102-25</b>	25'	.549 kgs (1.2 lbs)

Outside to outside  
Level/balcony or angle/rake  
Steel or wood posts

Drill Kit AX00.070.630  
Page 70



COD.	L	Wt.
<b>HFC18.401-5</b>	5'	.15 kgs (.331 lbs)
<b>HFC18.401-10</b>	10'	.227 kgs (.5 lbs)
<b>HFC18.401-15</b>	15'	.303 kgs (.669 lbs)
<b>HFC18.401-20</b>	20'	.383 kgs (.844 lbs)
<b>HFC18.401-25</b>	25'	.549 kgs (1.2 lbs)

Inside to inside  
Level/balcony

Drill Kit AX00.070.645  
Page 70

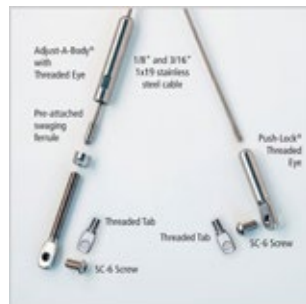

COD.	L	Wt.
<b>HFC18.500M-5</b>	5'	.15 kgs (.331 lbs)
<b>HFC18.500M-10</b>	10'	.227 kgs (.5 lbs)
<b>HFC18.500M-15</b>	15'	.303 kgs (.669 lbs)
<b>HFC18.500M-20</b>	20'	.383 kgs (.844 lbs)
<b>HFC18.500M-25</b>	25'	.549 kgs (1.2 lbs)

Inside to inside  
Level/balcony or angle/rake

Drill Kit AX00.070.650  
Page 70

AISI 316



1 x 19 Cable - 1/8" Diameter



COD.	L	Wt.
HFC18.262T-S-5	5'	.15 kgs (.331 lbs)
HFC18.262T-S-10	10'	.227 kgs (.5 lbs)
HFC18.262T-S-15	15'	.303 kgs (.669 lbs)
HFC18.262T-S-20	20'	.383 kgs (.844 lbs)
HFC18.262T-S-25	25'	.549 kgs (1.2 lbs)

Outside to outside  
Level/balcony

Drill Kit AX00.070.620  
Page 70



COD.	L	Wt.
HFC18.262T-A-5	5'	.15 kgs (.331 lbs)
HFC18.262T-A-10	10'	.227 kgs (.5 lbs)
HFC18.262T-A-15	15'	.303 kgs (.669 lbs)
HFC18.262T-A-20	20'	.383 kgs (.844 lbs)
HFC18.262T-A-25	25'	.549 kgs (1.2 lbs)

Outside to outside  
Angle/rake

Drill Kit AX00.070.620  
Page 70



COD.	L	Wt.
HFC18.601T-A-5	5'	.15 kgs (.331 lbs)
HFC18.601T-A-10	10'	.227 kgs (.5 lbs)
HFC18.601T-A-15	15'	.303 kgs (.669 lbs)
HFC18.601T-A-20	20'	.383 kgs (.844 lbs)
HFC18.601T-A-25	25'	.549 kgs (1.2 lbs)

Outside to inside  
Level/balcony

Drill Kit AX00.070.627  
Page 70



COD.	L	Wt.
HFC18.300-5	5'	.15 kgs (.331 lbs)
HFC18.300-10	10'	.227 kgs (.5 lbs)
HFC18.300-15	15'	.303 kgs (.669 lbs)
HFC18.300-20	20'	.383 kgs (.844 lbs)
HFC18.300-25	25'	.549 kgs (1.2 lbs)

Inside to inside  
Level/balcony

Drill Kit AX00.070.625  
Page 70



COD.	L	Wt.
HFC18.500-5	5'	.15 kgs (.331 lbs)
HFC18.500-10	10'	.227 kgs (.5 lbs)
HFC18.500-15	15'	.303 kgs (.669 lbs)
HFC18.500-20	20'	.383 kgs (.844 lbs)
HFC18.500-25	25'	.549 kgs (1.2 lbs)

Inside to inside  
Angle/rake

Drill Kit AX00.070.625  
Page 70



AISI 316



Available in 328' spool

COD.	Dim. mm	Length	kg/100 m
<b>AX00.040.215.B.M</b>	4 mm	100 m	6.14

### 1x19 Cable - Bulk

**Weight:**  
8.5 kgs (18.73 lbs)

COD.	G	mm	L1	L2	L3	D	A	kg/100
<b>AX00.050.220DX.B.SP</b>	M6	4.0	88.0	30.0	50.0	7.0	4.5	1.2

### Right handed cable terminal stud (DX)

**Weight:**  
.016 kgs (.035 lbs)

AISI 316

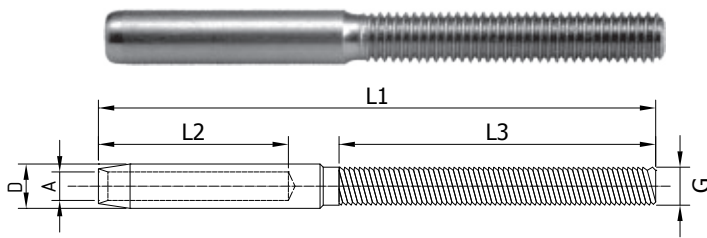

Hydraulic crimper



Page 72

Drill Kit **AX00.070.610**  
Page 70

COD.	G	mm	L1	L2	L3	D	A	kg/100
<b>AX00.050.221SX.B.SP</b>	M6	4.0	88.0	30.0	50.0	7.0	4.5	1.2

### Left handed cable terminal stud (SX)

**Weight:**  
.016 kgs (.035 lbs)

AISI 316

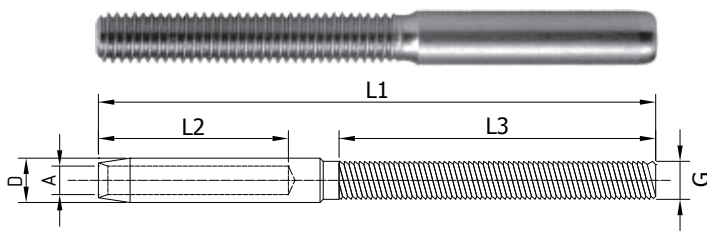

Hydraulic crimper



Page 72

Drill Kit **AX00.070.610**  
Page 70

AISI 316

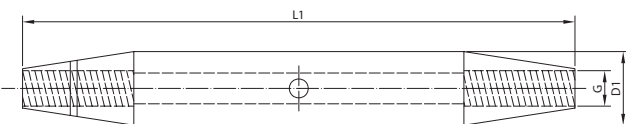

COD.	G	L1	D1	kg/100
<b>AX00.050.235.B.SP</b>	M6	65.0	10.0	1.7

### Middle-tensioning body

**Weight:**  
.025 kgs (.055 lbs)



COD.	NV	G	kg/100
<b>AX00.050.231SX.B.SP</b>	10	M6	0.9 LEFT
<b>AX00.050.230DX.B.SP</b>	10	M6	0.9 RIGHT

AISI 316

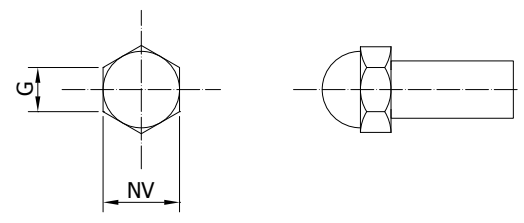

### Threaded nut cap tensioners

**Weight:**  
.006 kgs (.013 lbs)

Drill Kit **AX00.070.610**  
Page 70



COD.	d	Ø	e
<b>AX20.060.245.B.SP</b>	12 mm	42.4 mm	14 mm FLAT

### Sloping washer

**Weight:**  
.006 kgs (.013 lbs)

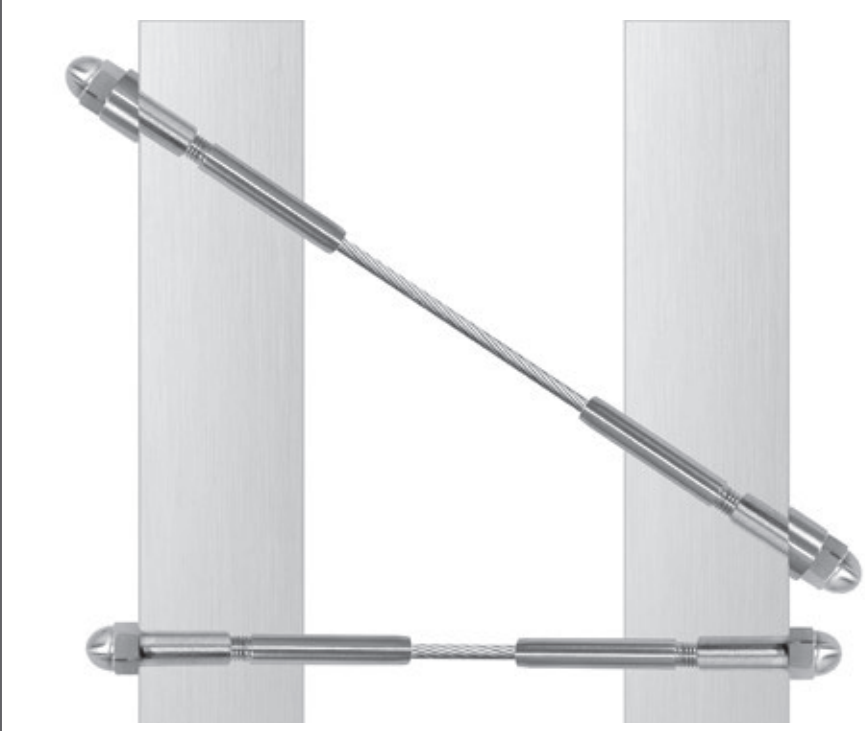
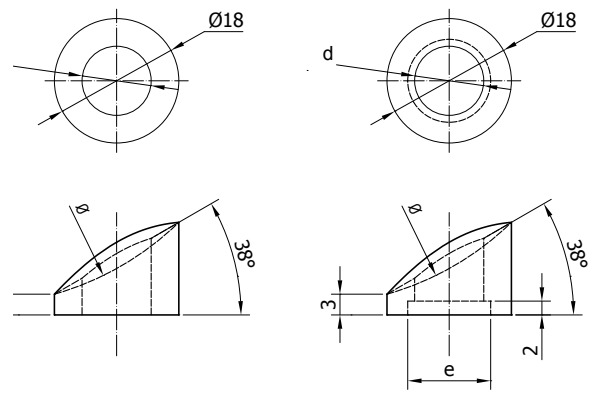



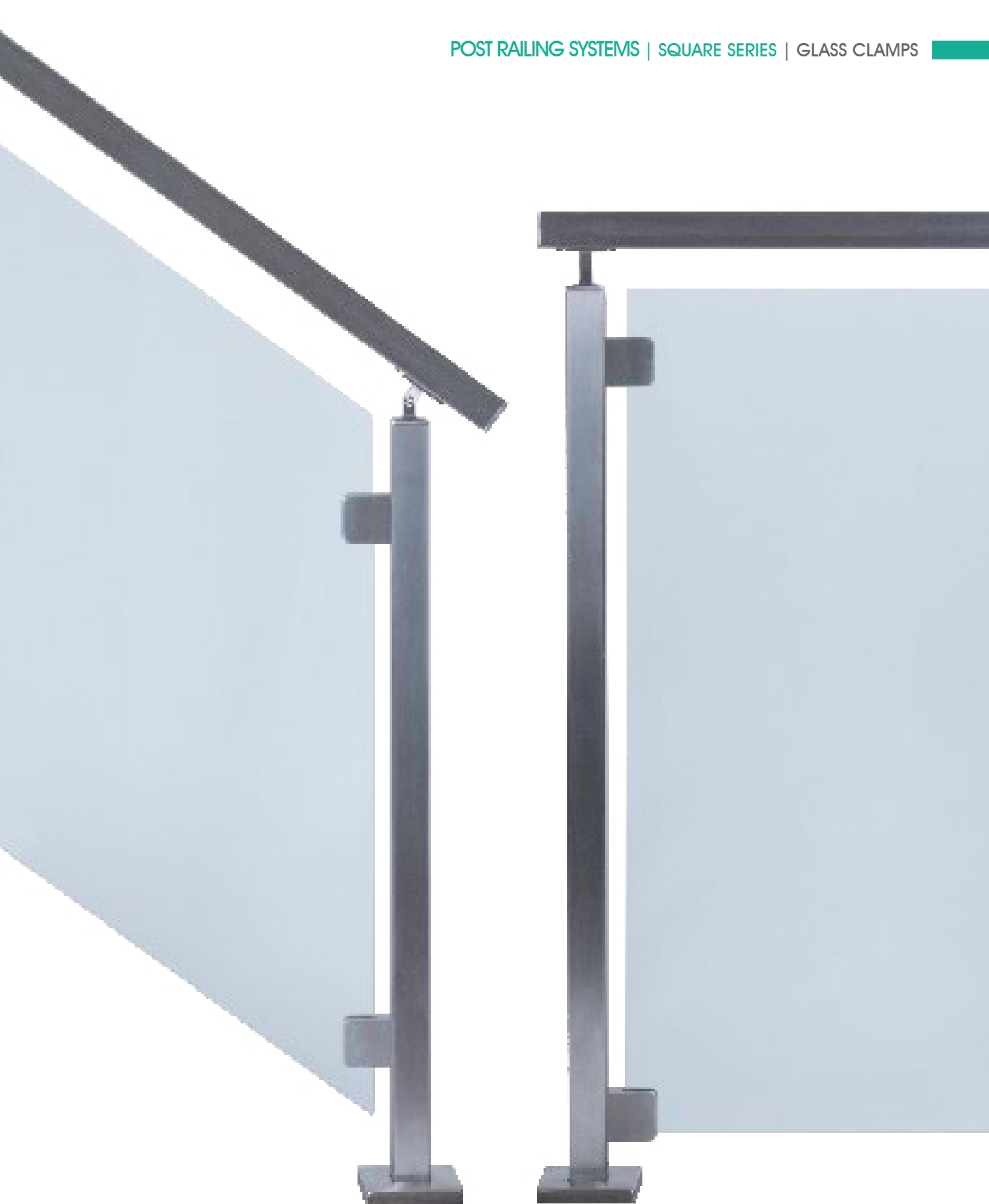



Swift plate and safety pin included

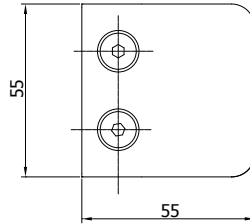
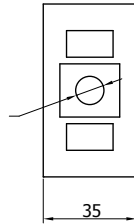
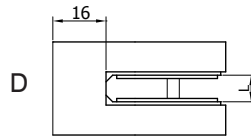

COD.	D	L
<b>AX20.014.190.A.SP</b>	flat	10 - 12.76 mm

Glass clamps for flat posts

**Weight:**  
.328 kgs (.727 lbs)

Rubber inserts not included  
Available for 3/8" & 1/2" monolithic glass

Quick# 255X  
Page 68



sold in pairs

COD.	T
<b>AX.20.014.191.R</b>	10 mm for 3/8" glass
<b>AX.20.014.192.R</b>	12 mm for 1/2" glass

Glass clamp inserts

T - indicates glass thickness

**Weight:**  
.009 kgs (.02 lbs)



COD.	Size
<b>AX00.090.266.A.SP</b>	M5
<b>AX00.090.267.A.SP</b>	M6
<b>AX00.090.269.A.SP</b>	M8

Pop rivets - threaded inserts

**Weight:**  
.045 kgs (.10 lbs)  
.068 kgs (.15 lbs)  
.113 kgs (.25 lbs)

Provides stronger connection of glass clamps to posts than standard tap/screw

Quick# 255X, 260X  
Page 68

Sold in packages of 25



Pop rivet tool

Page 72



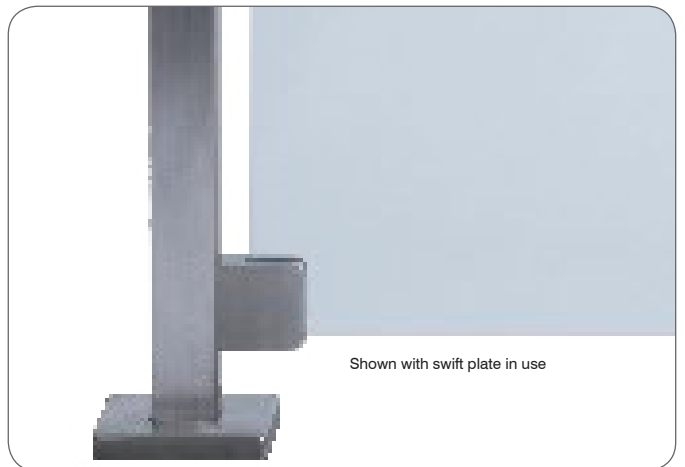

COD.	Ø	ØBase
<b>AX20.001.010.A.SP</b>	40 x 40 x 2 mm	100 x 100 mm

**Square post**

**Weight:**  
3.03 kgs (6.66 lbs)

Quick# 810X, 815X  
Page 68

Flange cover included

COD.	H	Ø	Wt.
<b>4000</b>	56"	3-1/4" x 3-1/4"	6.8 kgs (15 lbs)
<b>4923-41</b>	41"	1-3/4" x 1-3/4"	.907 kgs (2 lbs)

**Wood posts**

S-9403, S-9401  
Page 68

COD.	H	Ø	Wt.
<b>4000-CAP</b>	2"	3-1/4" x 3-1/4"	.261 kgs (.57 lbs)

**Post cap**

COD.	Ø
<b>AX20.003.012.A.SP</b>	40 x 40 x 2 mm

**Replacement flange cover**

**Weight:**  
.147 kgs (.323 lbs)

COD.	Ø
<b>AX20.001.011.A.SP</b>	40 x 40 x 2 mm

**Wall mount**

**Weight:**  
.727 kgs (1.6 lbs)

Quick# 900X, 905X  
Page 68

COD.	Ø	D
<b>AX20.001.013.D.M</b>	40 x 40 x 2 mm	

**Core mount**



**Weight:**  
.615 kgs (1.35 lbs)

COD.	Ø	D
<b>AX20.003.015.A.SP</b>	108 mm	40 x 54.2 mm

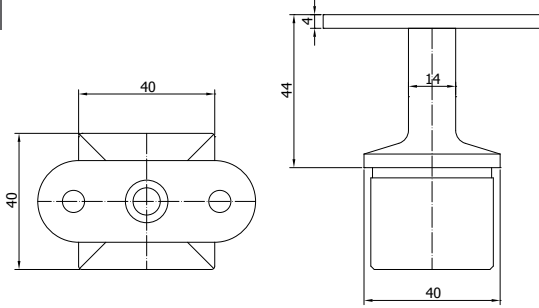

**Angled flange cover - core mount**

**Weight:**  
2.36 kgs (5.2 lbs)

up to 40 degrees

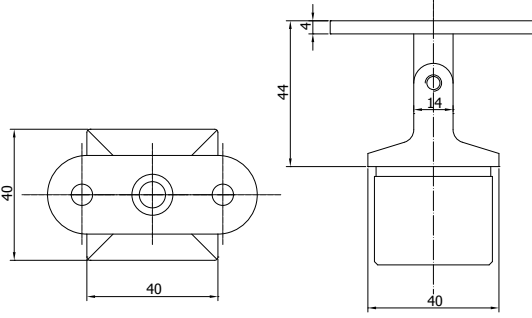
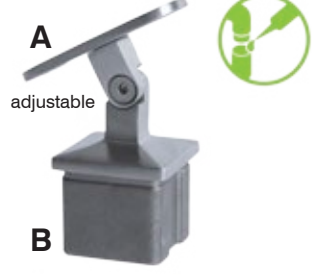
COD.	A	B
<b>AX20.005.030.A.SP</b>	flat	40 x 40 x 2 mm
<b>Post handrail support</b>		
<b>Weight:</b> .235 kgs (.517 lbs)		
 Quick# 250X, 540X Page 68		
		

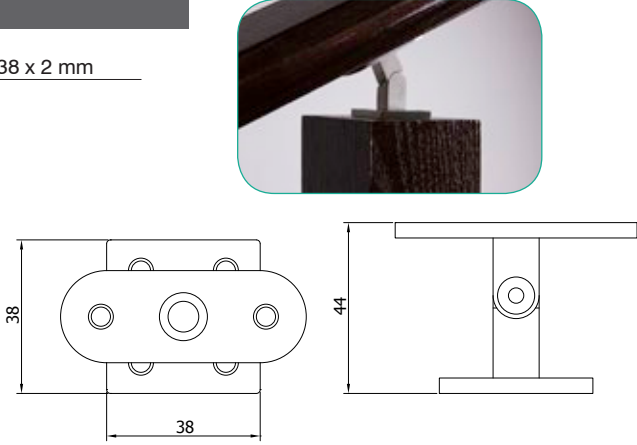
COD.	A	B
<b>AX20.005.031.A.SP</b>	flat	40 x 40 x 2 mm
<b>Adjustable post handrail support</b>		
<b>Weight:</b> .202 kgs (.444 lbs)		
 Quick# 250X, 540X Page 68		
		

COD.	A	B
<b>HF17.4001</b>	flat	38 x 38 x 2 mm
<b>Adjustable wood post handrail support</b>		
<b>Weight:</b> .181 kgs (.4 lbs)		
 Quick# 250X, 540X Page 68		
		

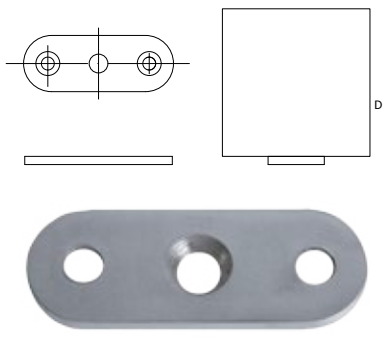
COD.	D
<b>AX10.005.025.A.SP</b>	flat
<b>Saddle</b>	
<b>Weight:</b> .035 kgs (.077 lbs)	
 Quick# 250X, 540X Page 68	
	

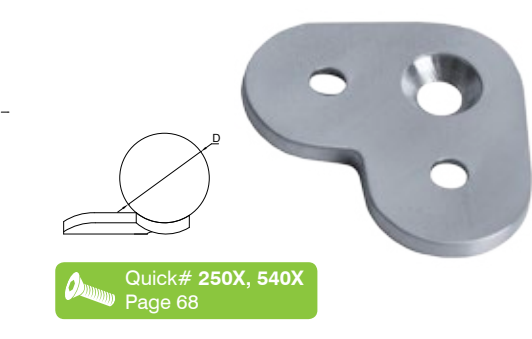
COD.	D
<b>AX10.005.023.A.SP</b>	flat
<b>Saddle - 90 degree</b>	
<b>Weight:</b> .036 kgs (.079 lbs)	
 Quick# 250X, 540X Page 68	
	

COD.	Ø	L	Wt.
<b>AX20.004.071.3000.A.SP</b>	40 x 40 x 2 mm	3000 mm	7.5 kgs (16.5 lbs)
<b>AX20.004.070.5800.A.SP</b>	40 x 40 x 2 mm	5800 mm	14.5 kgs (31.9 lbs)

Square Tube Handrail

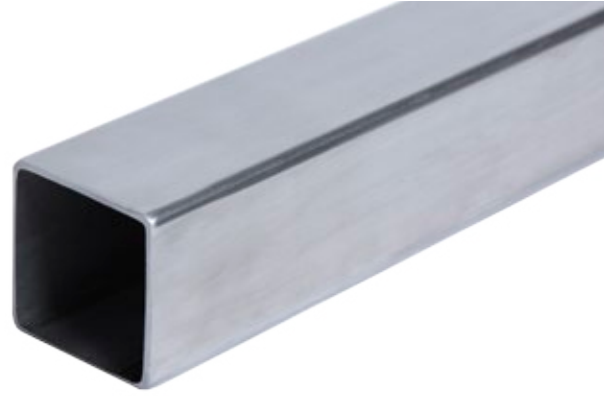

COD.	Ø	L	Wt.
<b>6084</b>	2-5/8" x 1-5/8"	16'	10.89 kgs (24 lbs)
<b>6084</b>	2-5/8" x 1-5/8"	8'	5.44 kgs (12 lbs)
<b>6002</b>	2-3/4" x 1-5/8"	16'	10.89 kgs (24 lbs)
<b>6002</b>	2-3/4" x 1-5/8"	8'	5.44 kgs (12 lbs)
<b>6060</b>	2" x 1-1/16"	16'	3.63 kgs (8 lbs)
<b>6060</b>	2" x 1-1/16"	8'	1.81 kgs (4 lbs)

Wood Handrail - Red Oak

Additional species available by special order

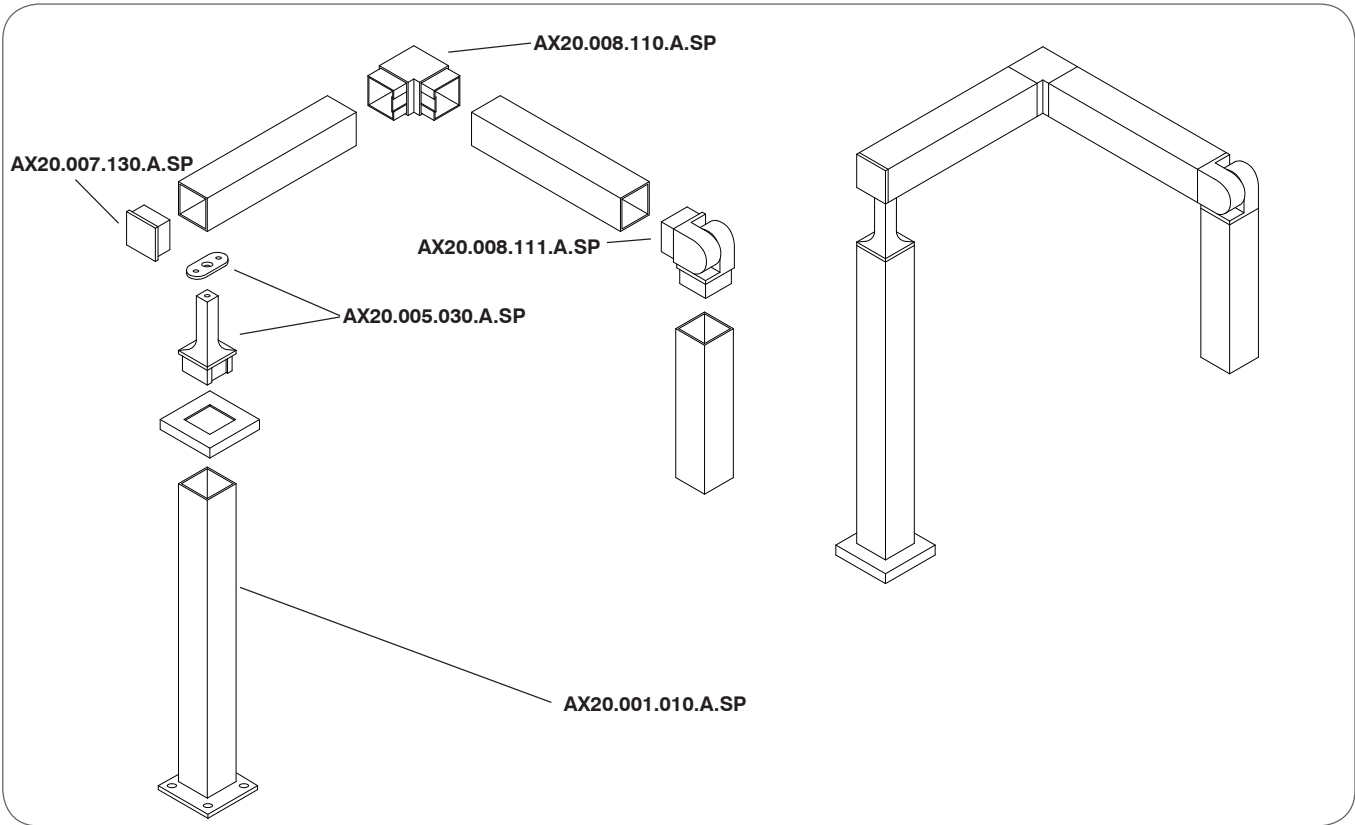

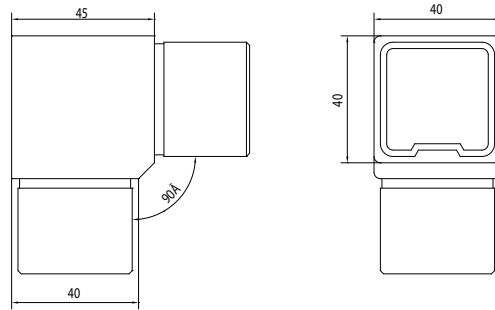

COD.  $\emptyset$

**AX20.008.110.A.SP** 40 x 40 x 2 mm

### 90 Degree elbow

**Weight:**  
.037 kgs (.184 lbs)

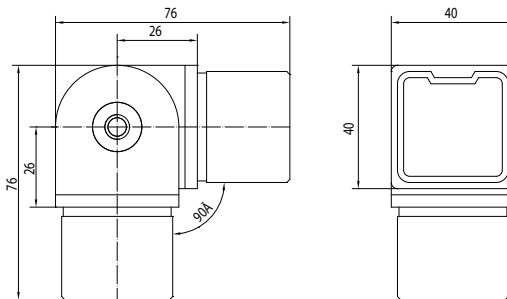

COD.  $\emptyset$

**AX20.008.111.A.SP** 40 x 40 x 2 mm

### Adjustable $\pm 90$ degree elbow

**Weight:**  
.546 kgs (1.2 lbs)

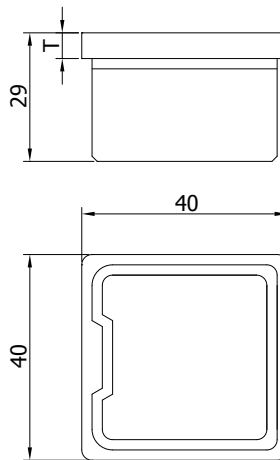

COD.  $\emptyset$

**AX20.007.130.A.SP** 40 x 40 x 2 mm

### End cap

**Weight:**  
.1 kgs (.22 lbs)

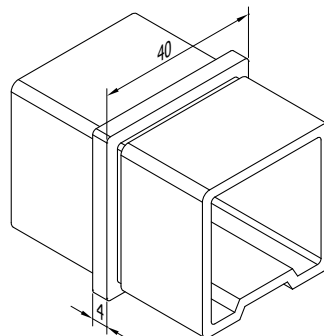
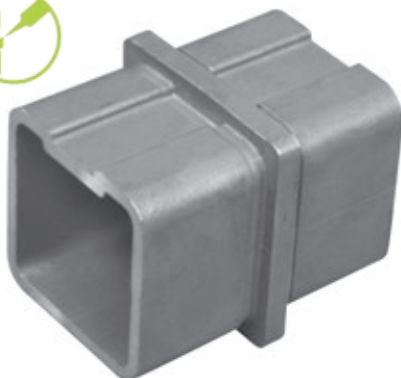

COD.  $\emptyset$

**AX20.008.112.A.SP** 40 x 40 x 2 mm

### Connector

**Weight:**  
.155 kgs (.341 lbs)

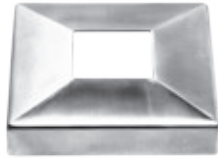

Flange cover included

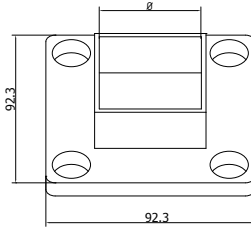

COD. Ø

**AX20.008.150.A.SP** 40 x 40 x 2 mm

Wall mount flange

**Weight:**  
.578 kgs (1.27 lbs)

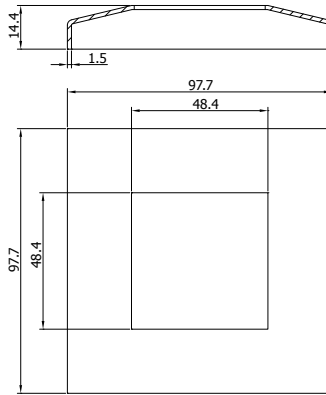
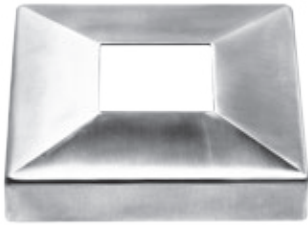

COD. Ø

**AX20.008.151.A.SP** 40 x 40 x 2 mm

Replacement cover for wall mount flange

**Weight:**  
.108 kgs (.238 lbs)

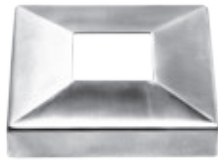
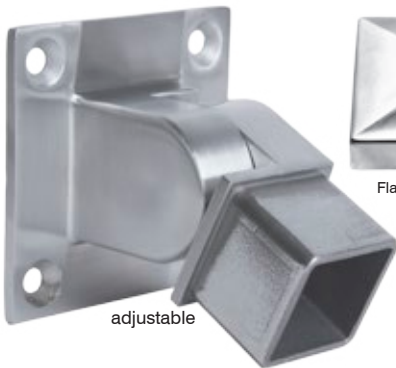

Flange cover included



adjustable

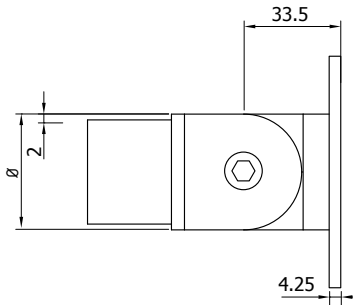

COD. Ø

**AX20.008.152.A.SP** 40 x 40 x 2 mm

Adjustable wall mount flange

**Weight:**  
.794 kgs (1.75 lbs)

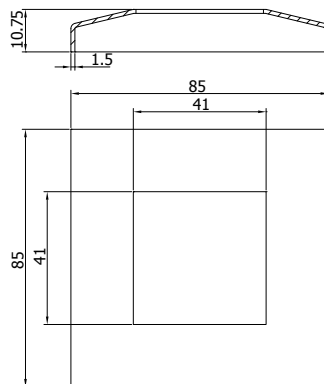
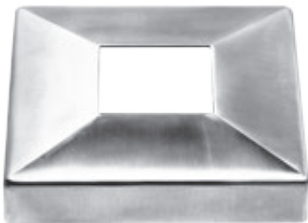
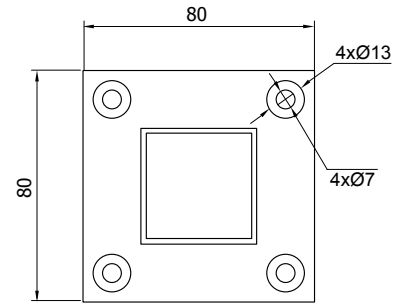

COD. Ø

**AX20.008.153.A.SP** 40 x 40 x 2 mm

Replacement cover for adjustable wall mount flange

**Weight:**  
.078 kgs (.172 lbs)

**COD.** D

**AX20.005.033.A.SP** flat

**Wall handrail support**

**Weight:**  
.328 kgs (.722 lbs)

Quick# 250X, 540X, 860X  
Page 68

**COD.** D

**HF17.4002** flat

**Wall handrail support**

**Weight:**  
.328 kgs (.722 lbs)

Quick# 250X, 540X  
Page 68

**COD.** D

**AX20.005.035.A.SP** flat

**Post handrail support**

**Weight:**  
.375 kgs (.825 lbs)

Quick# 250X, 540X, 260X  
Page 68

**COD.** D

**AX20.005.034.A.SP** flat

**Glass handrail support**

**Weight:**  
.623 kgs (1.37 lbs)

Quick# 250X, 540X  
Page 68







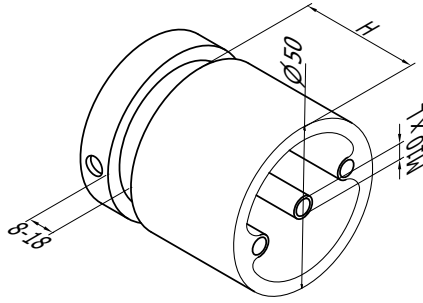

COD.	H	Glass Thickness
------	---	-----------------

AX30.017.040.A.SP	30.1 mm	8-18 mm
-------------------	---------	---------

**Glass standoff - round**

**Weight:**  
.543 kgs (1.17 lbs)

Quick# 900X, 905X  
Page 68



COD.	Thickness
------	-----------

AX30.017.042.F	1.25 mm
----------------	---------

**Glass leveling shim - round**

**Weight:**  
.011 kgs (.024 lbs)









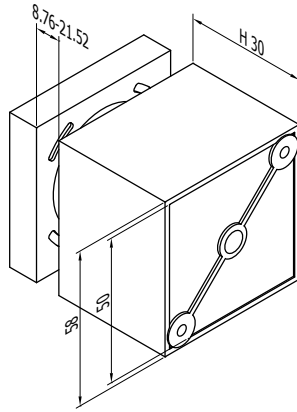

COD.	H	Glass Thickness
------	---	-----------------

AX30.017.041.A.SP	30 mm	8.76 - 21.52 mm
-------------------	-------	-----------------

**Glass standoff - square**

**Weight:**  
.649 kgs (1.43 lbs)

Quick# 900X, 905X  
Page 68

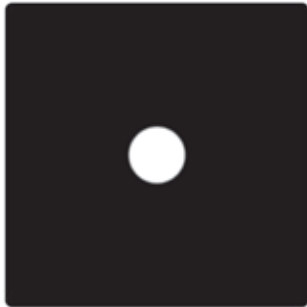
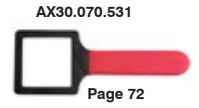

COD.	Thickness
------	-----------

AX30.017.043.F	1.25 mm
----------------	---------

**Glass leveling shim - square**

**Weight:**  
.013 kgs (.029 lbs)



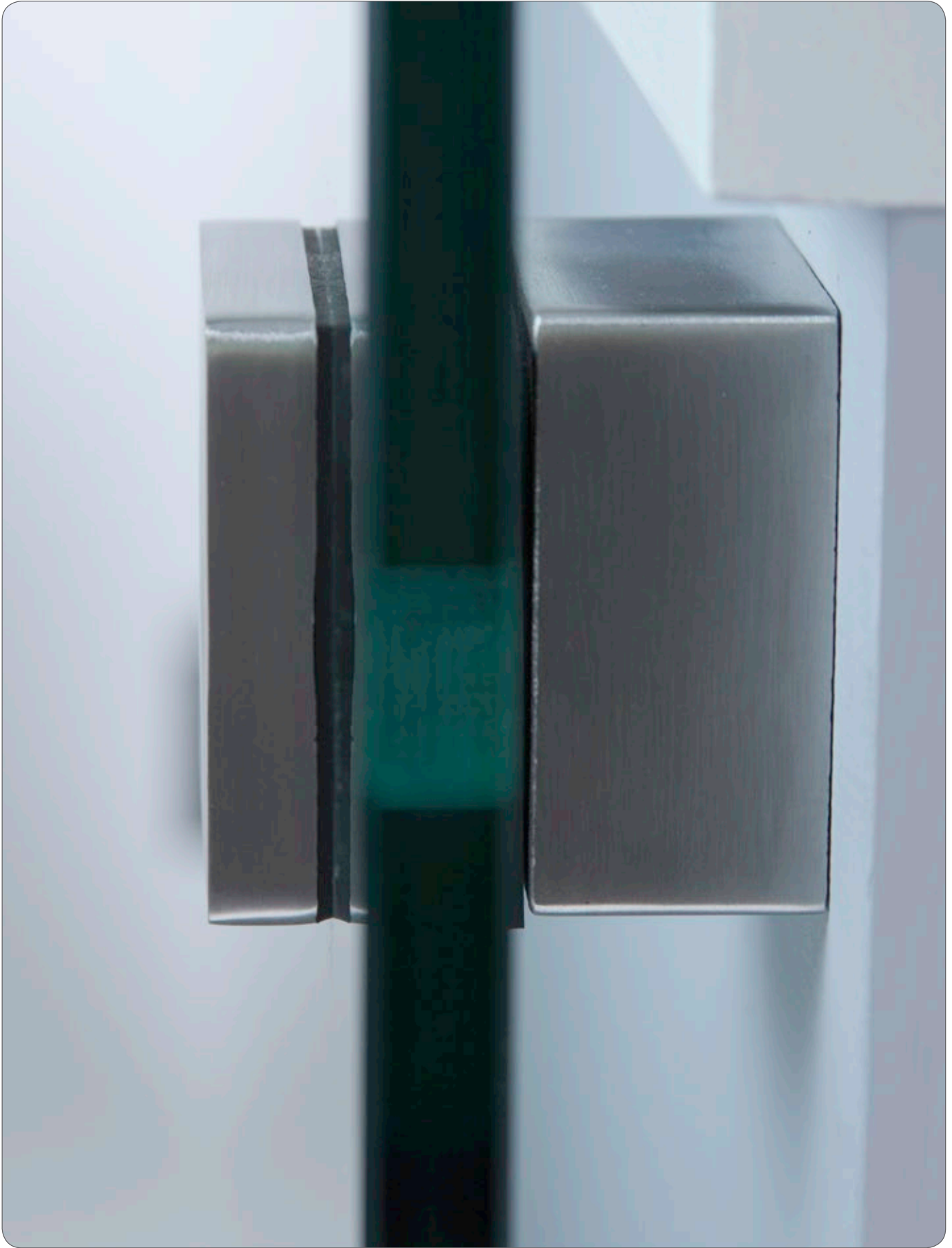







Floor mount



Wall mount

COD.	dim.	L.	Wt.
<b>AX40.020.050.D.M</b>	121 x 43 mm	5000 mm	24.59 kgs (54.78lbs)
Includes 2 glass gaskets and wedges sets			
<b>AX40.020.051.D.M</b>	121 x 43 mm	2500 mm	12.45 kgs (27.39 lbs)
Includes 1 glass gaskets and wedges set			

**Floor mount profile**

Quick# 885X, 890X, 895X, 899X  
Page 68



Satin Aluminum finish

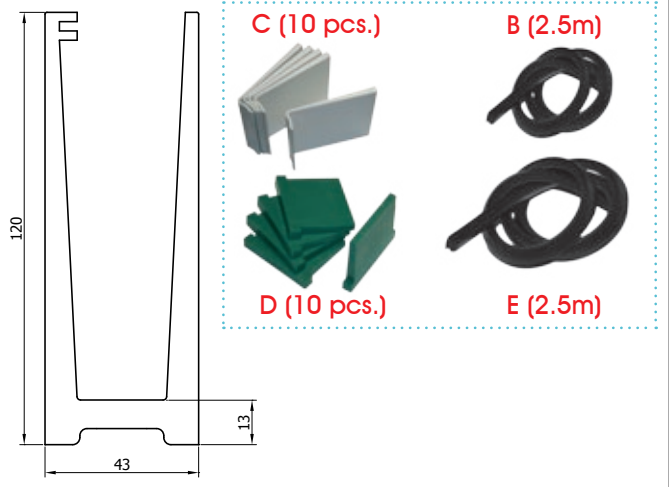

COD.	dim.	L.	Wt.
<b>AX40.024.279.A.SP</b>	123 mm	2500 mm	3.62 kgs (7.96 lbs)

**Stainless steel cladding for floor profile**



self adhesive

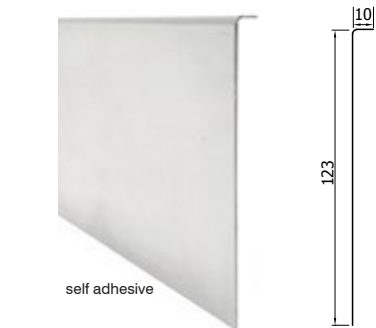

COD.	dim.	L.	Wt.
<b>AX40.020.052.D.M</b>	119 x 45 mm	5000 mm	25.52 kgs (56.14 lbs)
Includes 2 glass gaskets and wedges sets			
<b>AX40.020.053.D.M</b>	119 x 45 mm	2500 mm	12.76 kgs (28.07 lbs)
Includes 1 glass gaskets and wedges set			

**Wall mount profile**

Quick# 885X, 890X, 895X, 899X  
Page 68



**AX40.020.055.D.SP**  
**Hole plugs**  
For use when cladding will not be installed

Satin Aluminum finish

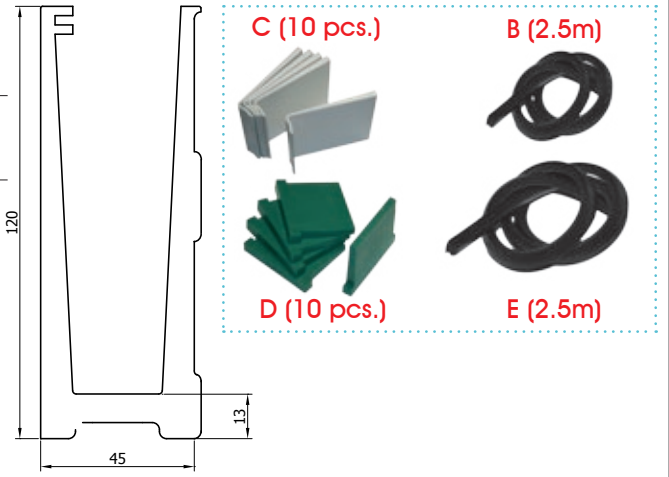

COD.	dim.	L.	Wt.
<b>AX40.024.280.A.SP</b>	122 mm	2500 mm	3.62 kgs (7.96 lbs)

**Stainless steel cladding for wall profile**



self adhesive

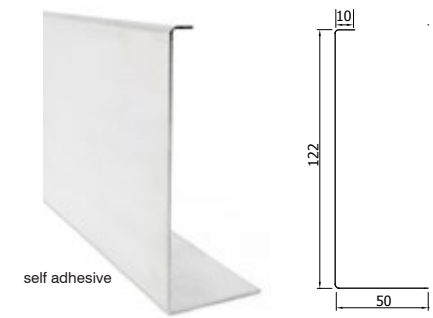

COD.

**AX40.021.285.R**

### Wedge kit

Wedge kits are included with U Channel  
This part is sold separately to provide additional shims

**Weight:**  
1.41 kgs (3.11 lbs)

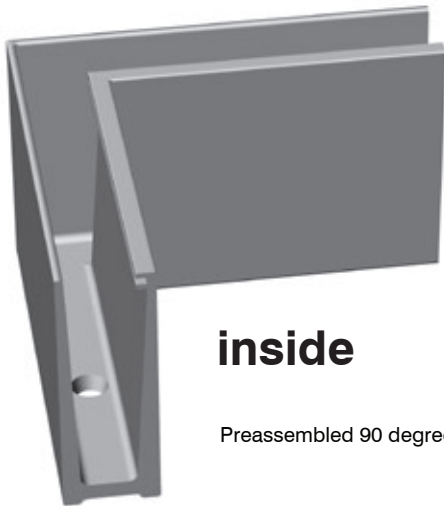
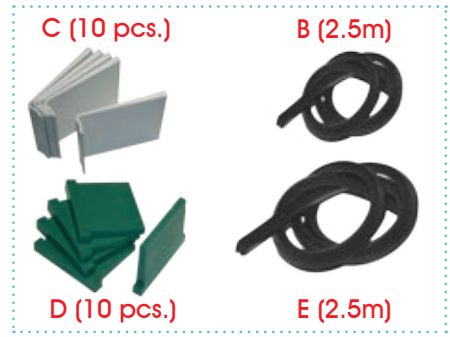

### inside

Preassembled 90 degree corner

### Floor profile

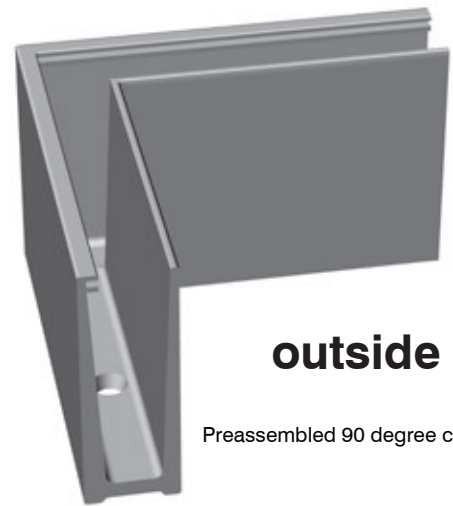

### outside

Preassembled 90 degree corner

COD.	dim.	L.
<b>AX40.023.272.D.M</b>	120 x 45 mm	200 mm

**Inside corner for floor profile** **Weight:**  
1.75 kgs (3.85 lbs)

COD.	dim.	L.
<b>AX40.023.274.D.M</b>	120 x 45 mm	200 mm

**Outside corner for floor profile** **Weight:**  
1.75 kgs (3.85 lbs)



### inside

Preassembled 90 degree corner

### Wall profile

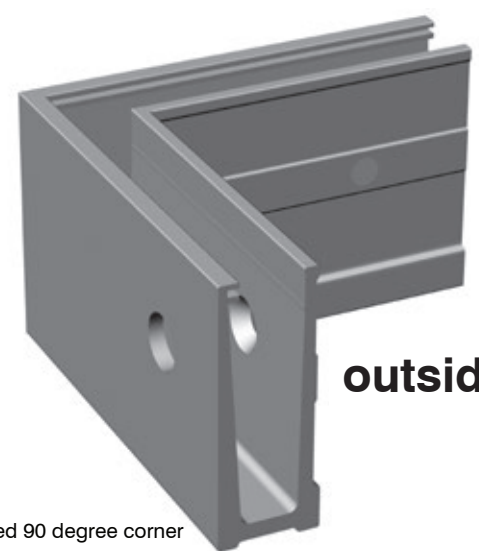

### outside

Preassembled 90 degree corner

COD.	dim.	L.
<b>AX40.023.276.D.M</b>	120 x 43 mm	200 mm

**Inside corner for wall profile** **Weight:**  
1.79 kgs (3.95 lbs)

COD.	dim.	L.
<b>AX40.023.278.D.M</b>	120 x 43 mm	200 mm

**Outside corner for wall profile** **Weight:**  
1.79 kgs (3.95 lbs)

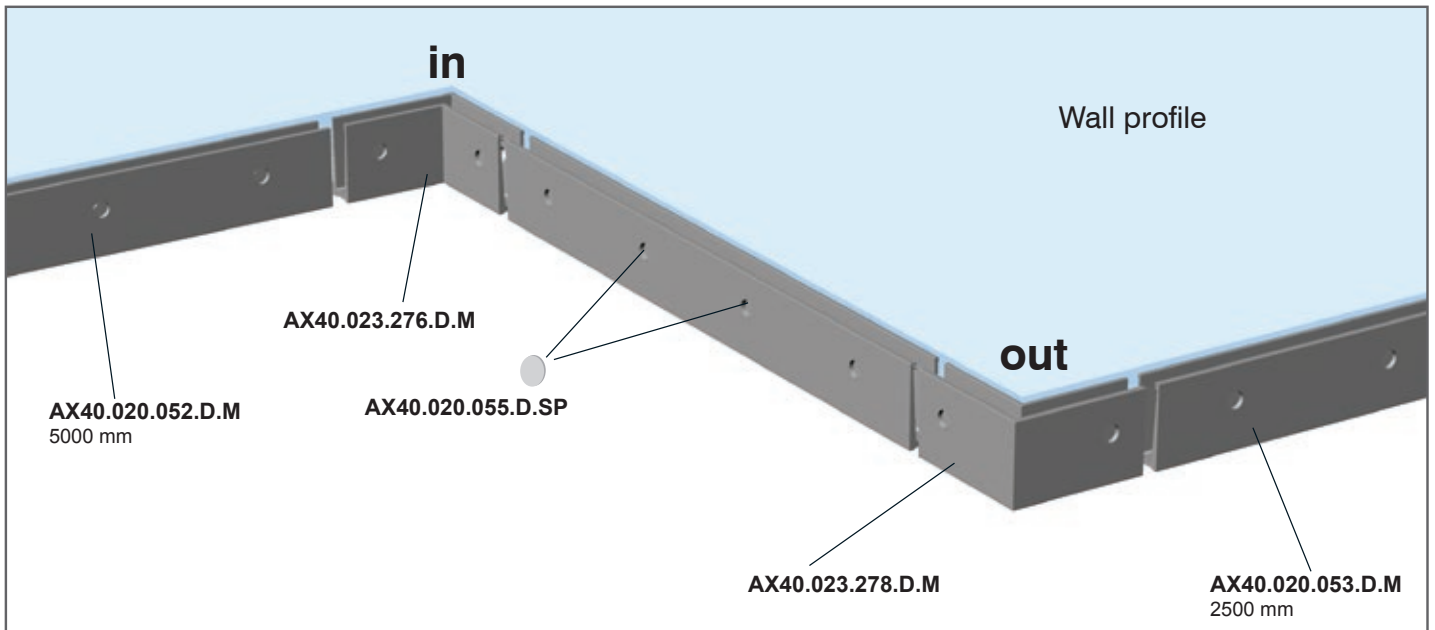
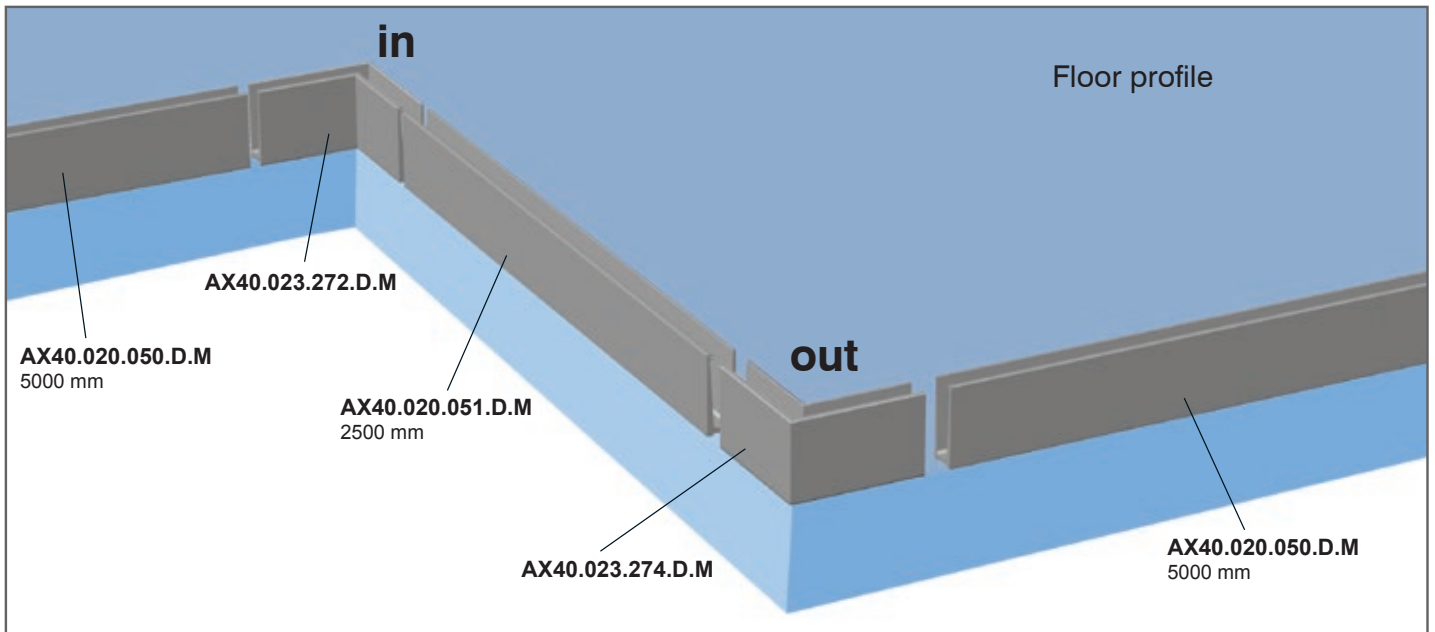

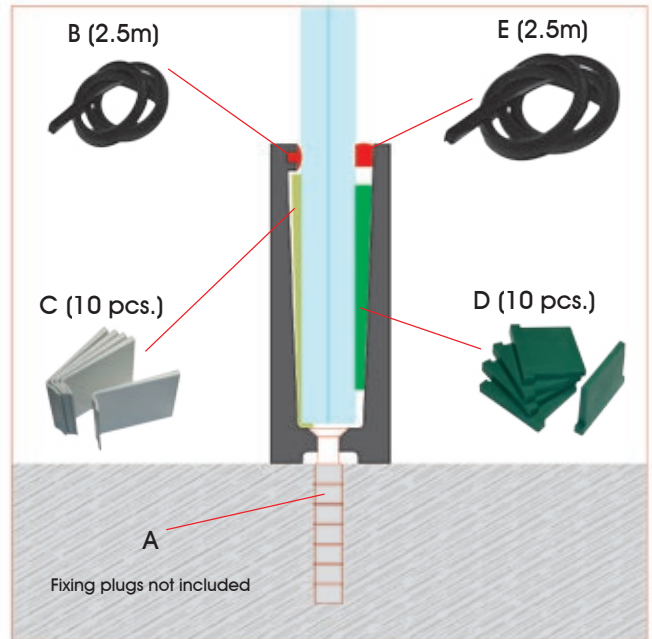
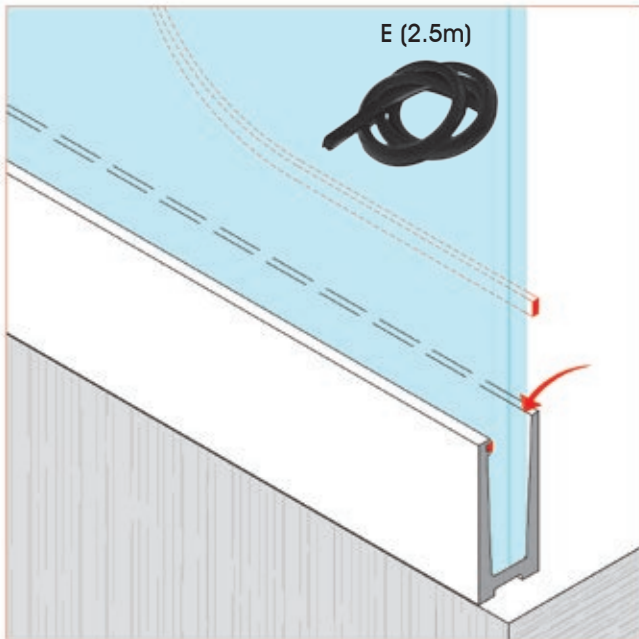
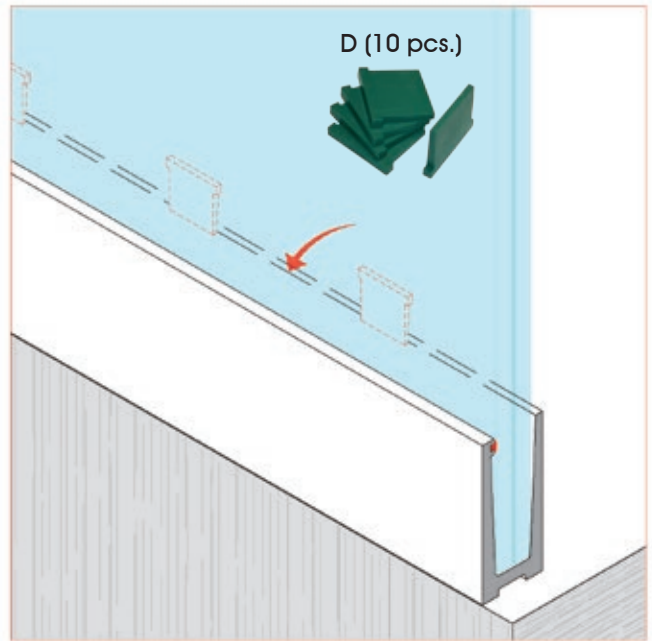
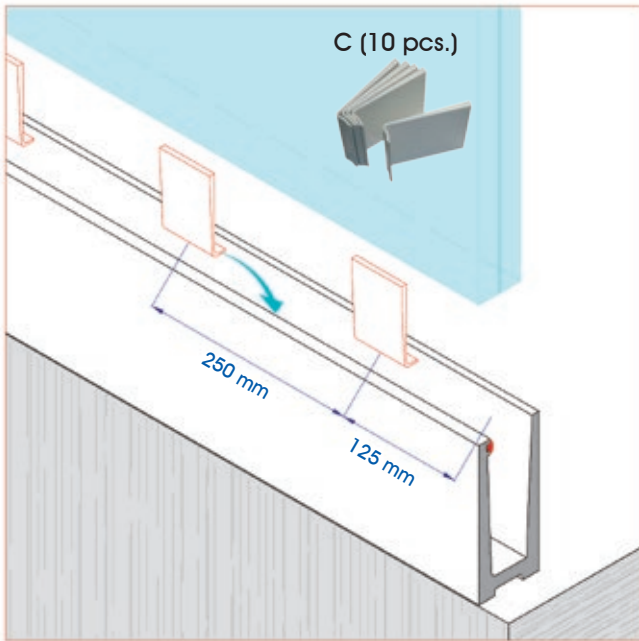
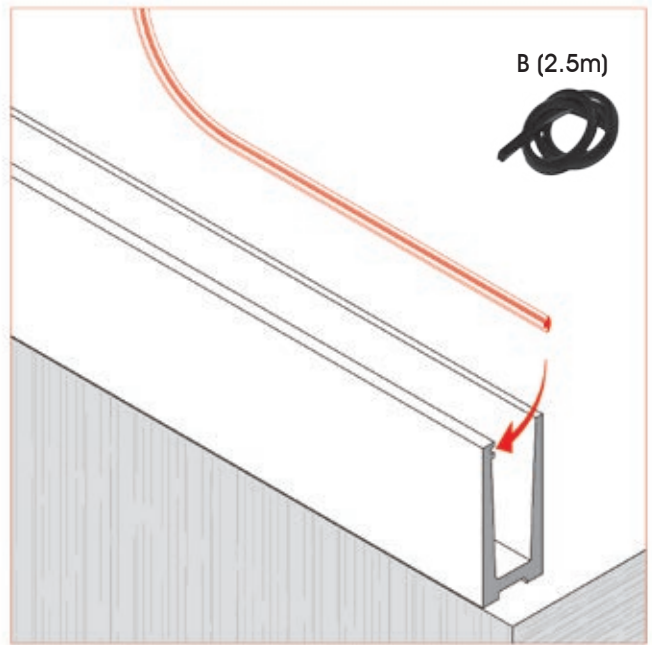
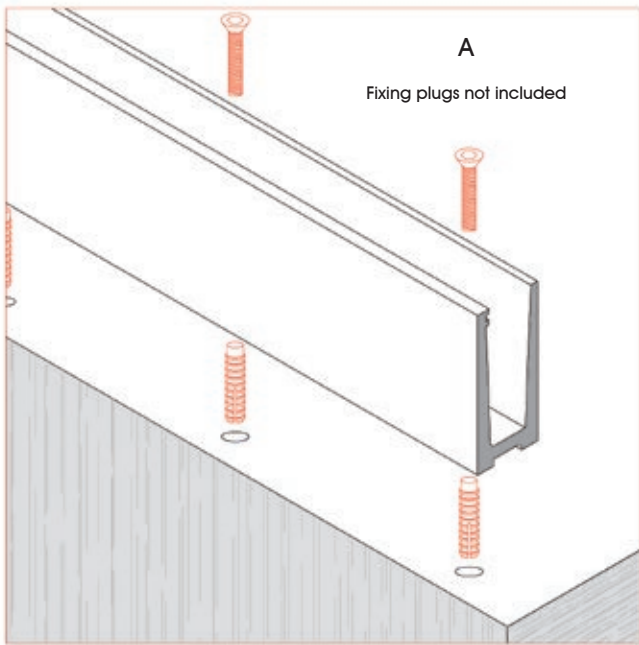

COD.

AX40.020.281.D.SP

End cap - Floor profile - Level/balcony

Weight:  
.02 kgs (.044 lbs)



Satin Finish Aluminium

COD.

AX40.020.283.D.SP

End cap - Floor profile - Angle/rake

up to 40 degrees

Weight:  
.026 kgs (.057 lbs)



Satin Finish Aluminium

COD.

AX40.020.282.D.SP

End cap - Wall profile - Level/balcony

Weight:  
.021 kgs (.046 lbs)



Satin Finish Aluminium

COD.

AX40.020.284.D.SP

End cap - Wall profile - Angle/rake

up to 40 degrees

Weight:  
.027 kgs (.059 lbs)



Satin Finish Aluminium

COD.

AX40.022.270.A.SP

Drainage spacer

Weight:  
.040 kgs (.087 lbs)



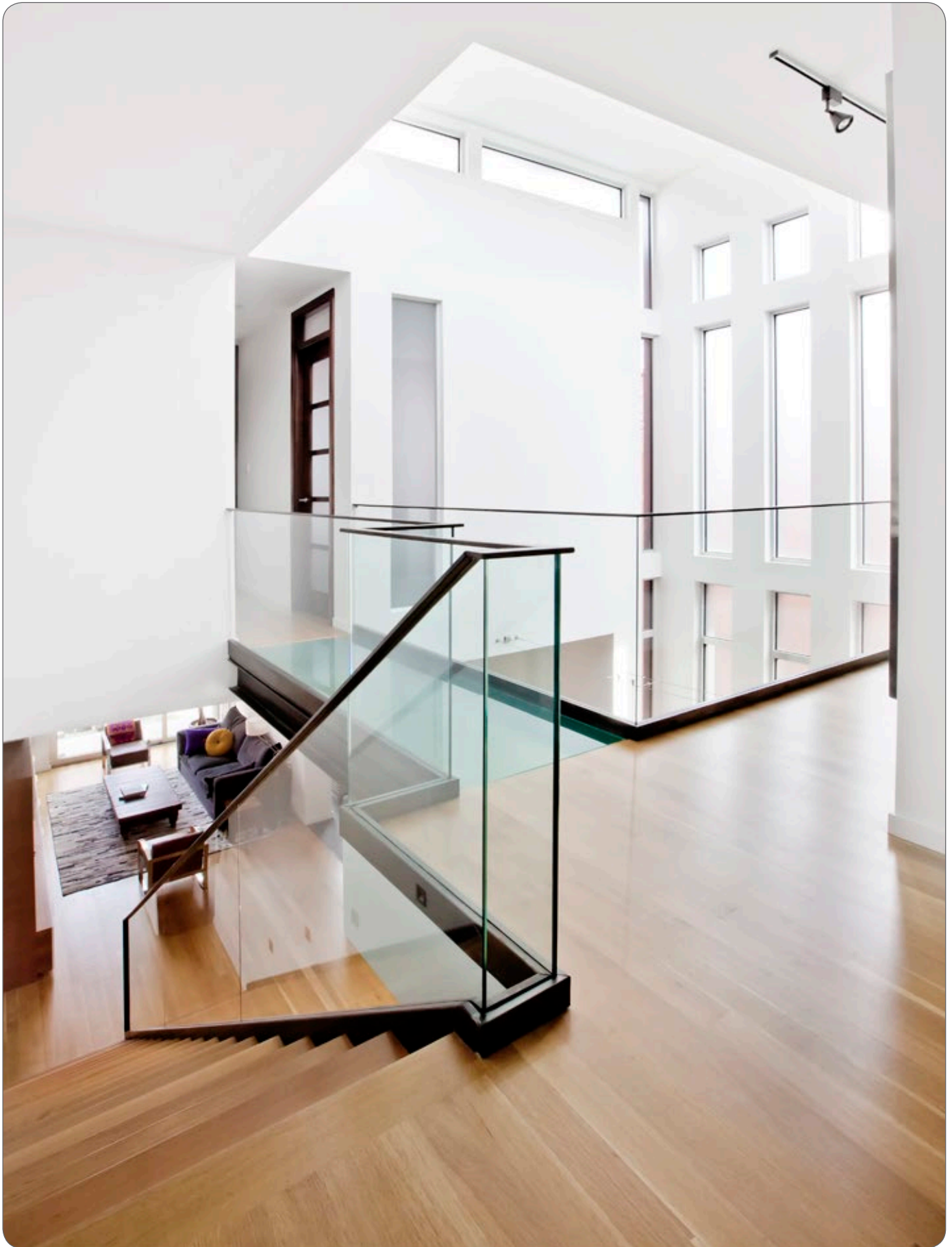









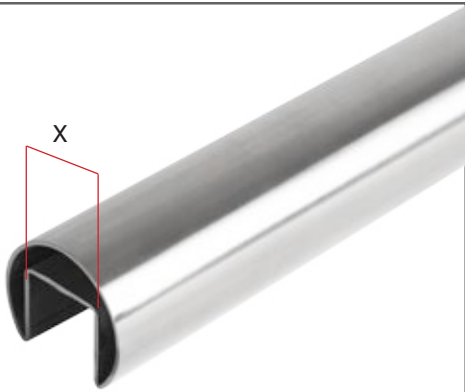
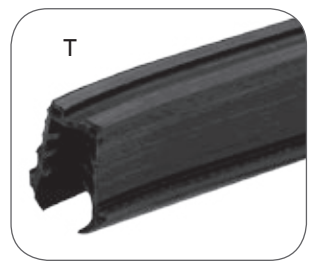
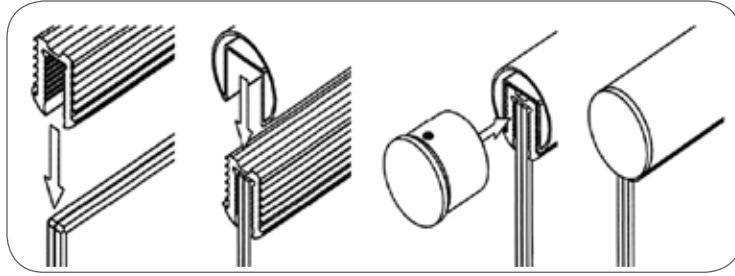



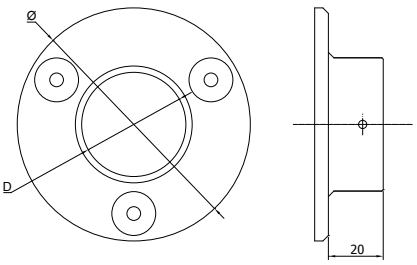

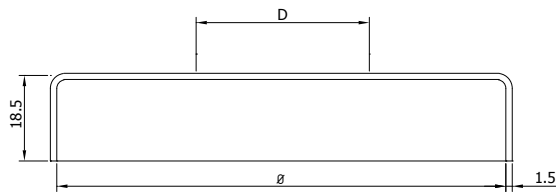



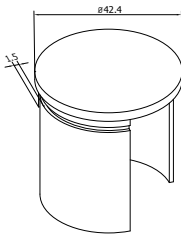

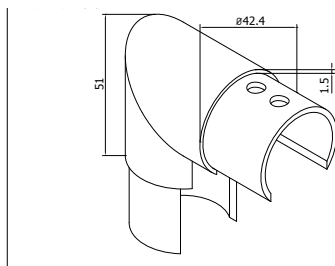

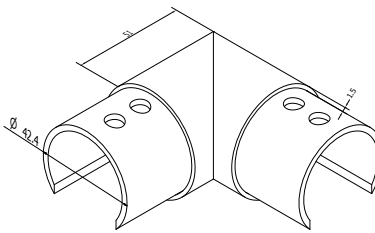

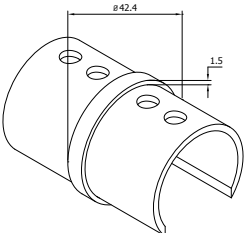
COD.	Ø	T	X	L
<b>AX00.030.065.A.SP</b>	42.4 x 1.5 mm		24 x 24 mm	5000 mm
Rubber not included <b>Glass cap rail</b> <b>Weight:</b> 10.2 kgs (22.4 lbs)				
<b>AX00.031.072.R</b>	42.4 x 1.5 mm	13.52 mm	24 x 24 mm	5000 mm
<b>Rubber washer</b> <b>Weight:</b> 2.34 kgs (5.15 lbs)				

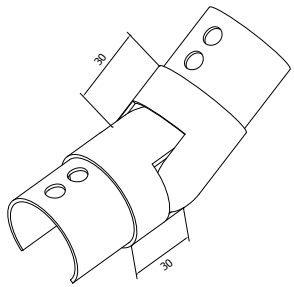
COD.	Ø
<b>AX00.032.175.A.SP</b>	42.4 x 1.5 mm
<b>Wall mount flange</b> <b>Weight:</b> .2 kgs (.44lbs)	
 <p>Fits up to 1/2" glass      Flange cover included</p>	
	
	
<b>AX00.032.176.A.SP</b>	42.4 x 1.5 mm
<b>Replacement wall mount flange cover</b> <b>Weight:</b> .1 kgs (.219 lbs)	
	
	
 <p>Slotted flange cover allows glass to be installed 1/4" from wall</p>	

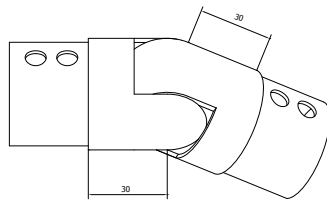
<p>COD. <math>\emptyset</math></p> <p><b>AX00.030.120.A.SP</b> 42.4 x 1.5 mm</p> <p><b>Flat end cap</b></p> <p><b>Weight:</b> .084 kgs (.184 lbs)</p>		 
<p>COD. <math>\emptyset</math></p> <p><b>AX00.032.171.A.SP</b> 42.4 x 1.5 mm</p> <p><b>Vertical elbow</b></p> <p><b>Weight:</b> .332 kgs (.73 lbs)</p>		 
<p>COD. <math>\emptyset</math></p> <p><b>AX00.032.170.A.SP</b> 42.4 x 1.5 mm</p> <p><b>Horizontal elbow</b></p> <p><b>Weight:</b> .297 kgs (.653 lbs)</p>		 
<p>COD. <math>\emptyset</math></p> <p><b>AX00.032.174.A.SP</b> 42.4 x 1.5 mm</p> <p><b>Connector</b></p> <p><b>Weight:</b> .104 kgs (.289 lbs)</p>		 
<p>COD. <math>\emptyset</math></p> <p><b>AX00.032.172.A.SP</b> 42.4 x 1.5 mm</p> <p><b>Adjustable elbow - upward</b></p> <p><b>Weight:</b> .3 kgs (.66 lbs)</p>		 
<p>COD. <math>\emptyset</math></p> <p><b>AX00.032.173.A.SP</b> 42.4 x 1.5 mm</p> <p><b>Adjustable elbow - downward</b></p> <p><b>Weight:</b> .321 kgs (.706 lbs)</p>		 

COD.	Ø	T	X	L
<b>AX00.030.071.A.SP</b>	42.4 x 1.5 mm		24 x 24 mm	5000 mm
Rubber not included <b>Square cap rail</b> <b>Weight:</b> 12.4 kgs (27.28 lbs)				
<b>AX00.031.072.R</b>	42.4 x 1.5 mm	13.52 mm	24 x 24 mm	6000 mm
<b>Rubber washer</b> <b>Weight:</b> 2.34 kgs (5.15 lbs)				

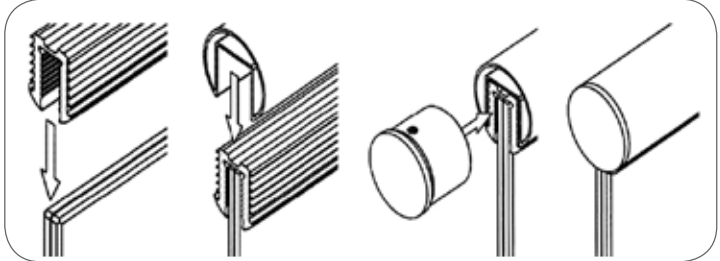
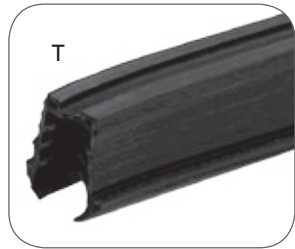
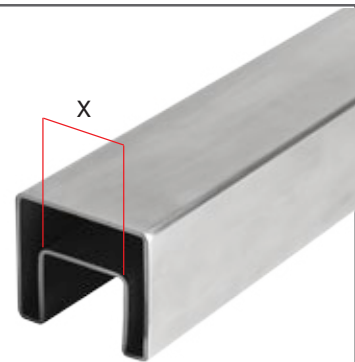

COD.	Ø	T	X	L	Wt.
<b>AX00.030.073.G.RW</b>	1.57" x 1.57"		24 x 24 mm	16'	5.81 kgs (12.8 lbs)
<b>AX00.030.074.G.RW</b>	1.57" x 1.57"		24 x 24 mm	8'	2.9 kgs (6.4 lbs)
<b>Red Oak wood cap rail</b> Rubber not included					
<b>AX00.030.080.G.RW</b>	1.57" x 1.57"		24 x 24 mm	16'	5.81 kgs (12.8 lbs)
<b>AX00.030.084.G.RW</b>	1.57" x 1.57"		24 x 24 mm	8'	2.9 kgs (6.4 lbs)
<b>White Oak wood cap rail</b> Rubber not included					
<b>AX00.031.072.R</b>	42.4 x 1.5 mm	13.52 mm	24 x 24 mm	6000 mm	2.34 kgs (5.15 lbs)
<b>Rubber washer</b>					

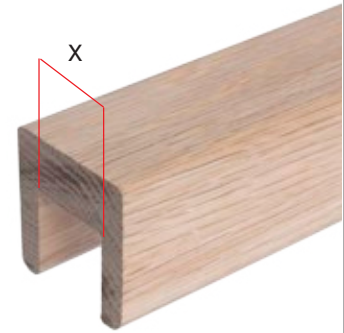

Additional species available by special order

COD.	Ø
<b>AX00.032.324.A.SP</b>	42.4 x 1.5 mm
<b>Wall mount flange</b>	
<b>Weight:</b> .211 kgs (.464 lbs)	

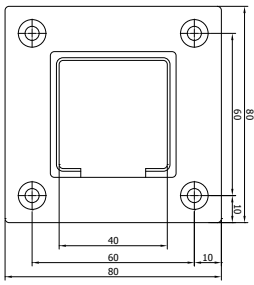

Flange cover included

COD.	Ø
<b>AX00.003.325.A.SP</b>	42.4 x 1.5 mm
<b>Replacement wall mount flange cover</b>	
<b>Weight:</b> .105 kgs (.231 lbs)	







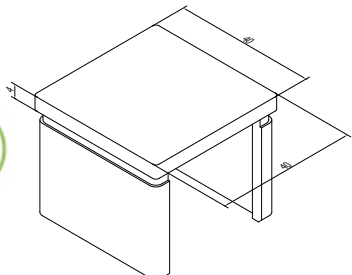



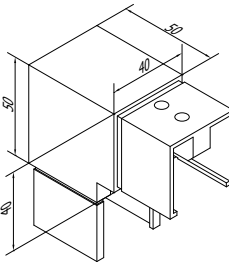

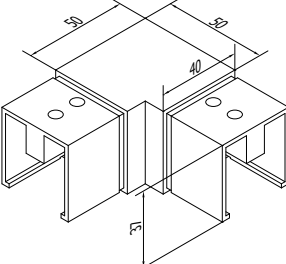

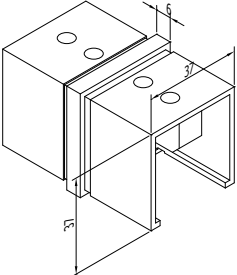
Quick# 820X  
Page 68

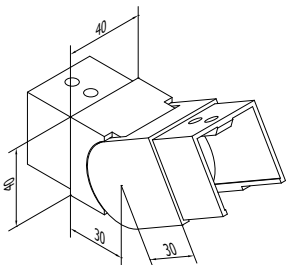

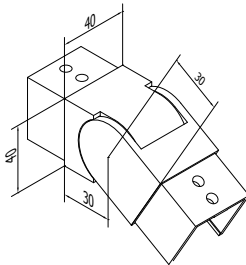

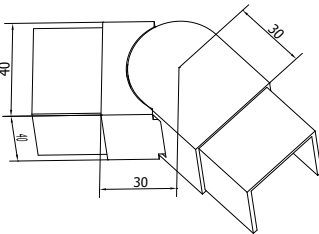
COD.	Ø
<b>AX00.032.322.A.SP</b>	42.4 x 1.5 mm
<b>Flat end cap</b>	
<b>Weight:</b> .114 kgs (.251 lbs)	















Slotted flange cover allows glass to be installed 1/4" from wall

<p>COD. <span style="float: right;">Ø</span></p> <p><b>AX00.032.326.A.SP</b> <span style="float: right;">42.4 x 1.5 mm</span></p> <p><b>Vertical elbow</b></p> <p><b>Weight:</b> .428 kgs (.942 lbs)</p>		
<p>COD. <span style="float: right;">Ø</span></p> <p><b>AX00.032.305.A.SP</b> <span style="float: right;">42.4 x 1.5 mm</span></p> <p><b>Horizontal elbow</b></p> <p><b>Weight:</b> .367 kgs (.807 lbs)</p>		
<p>COD. <span style="float: right;">Ø</span></p> <p><b>AX00.032.320.A.SP</b> <span style="float: right;">42.4 x 1.5 mm</span></p> <p><b>Connector</b></p> <p><b>Weight:</b> .176 kgs (.387 lbs)</p>		
<p>COD. <span style="float: right;">Ø</span></p> <p><b>AX00.032.310.A.SP</b> <span style="float: right;">42.4 x 1.5 mm</span></p> <p><b>Adjustable elbow - upward</b></p> <p><b>Weight:</b> .411 kgs (.904 lbs)</p>		
<p>COD. <span style="float: right;">Ø</span></p> <p><b>AX00.032.311.A.SP</b> <span style="float: right;">42.4 x 1.5 mm</span></p> <p><b>Adjustable elbow - downward</b></p> <p><b>Weight:</b> .436 kgs (.962 lbs)</p>		
<p>COD. <span style="float: right;">Ø</span></p> <p><b>AX00.032.315.A.SP</b> <span style="float: right;">42.4 x 1.5 mm</span></p> <p><b>Adjustable horizontal elbow</b></p> <p><b>Weight:</b> .365 kgs (.803 lbs)</p>		

System Hardware

	Quick#	Part#	Dimensions/Quantity per item	Function	Package Quantity
	250X	AX00.090.250.A.SP	M5 x 12 mm (QTY 2)	Attaches saddle to metal handrail	25
	540X	AX00.090.540.A.SP	4.8 x 25 mm (QTY 2)	Attaches saddle to wood handrail	25
	265X	AX00.090.265.A.SP	M6 x 10 mm (QTY 1)	Attaches saddle to stem (Replacement)	25
	260X	AX00.090.260.A.SP	M6 x 20 mm (QTY 1)	Attaches bar holder to metal post	25
	255X	AX00.090.255.A.SP	M8 x 25 mm (QTY1)	Attaches glass clamp to metal post	25

Anchors

	Quick#	Part#	Dimensions/Quantity per item	Function	Package Quantity
	800X	AX00.090.800.A.SP	3/8 X 3 1/2" Wood lag bolts (QTY 3)	Round newel post mount	3
	805X	AX00.090.805.A.SP	3/8 X 3 1/2" Concrete wedge anchors (QTY 3)	Round newel post mount	3
	810X	AX00.090.810.A.SP	3/8 x 3 1/2" Lag bolts to wood floor (QTY 2)	Square newel post mount	2
	815X	AX00.090.815.A.SP	3/8 x 3 1/2" Concrete wedge anchors (QTY 2)	Square newel post mount	2
	820X	AX00.090.820.A.SP	#10 x 3" Wood screw to attach to wall (QTY 4)	Square cap rail wall mount flange	4
	825X	AX00.090.825.A.SP	#10 x 3" Wood screw to attach to wall (QTY 3)	Round cap rail wall mount flange	3
	830X	AX00.090.830.A.SP	#14 x 3" Wood screw to attach to wall (QTY 3)	Round adjustable angle wall rail fitting	3
	835X	AX00.090.835.A.SP	#14 X 3" Flat head wood screw (QTY 4)	Square adjustable angle wall rail fitting	4
	840X	AX00.090.840.A.SP	#14 X 3" Wood screw to attach to wall (QTY 4)	Square wall mount flange	4
	845X	AX00.090.845.A.SP	#10 X 3" Wood screw to attach to wall (QTY 3)	Round wall mount flange	3
	850X	AX00.090.850.A.SP	#14 X 3" Flat head wood screw (QTY 3)	Round wall Rail return	3
	855X	AX00.090.855.A.SP	#12 X 3" Flat head wood screw (QTY 3)	Round wall Rail Bracket	3
	860X	AX00.090.860.A.SP	#12 X 3" Flat head wood screw (QTY 2)	Square wall Rail Bracket	2
	865X	AX00.090.865.A.SP	M6 x 76 Socket head wood screw (QTY 2)	Square side mount post bracket	2
	870X	AX00.090.870.A.SP	#16 X 3" Flat head wood screw (QTY 4)	Round side mount post bracket	4
	875X	AX00.090.875.A.SP	1/2 x 3 1/2 Flat head wood screw (QTY 2)	U Channel 90 degree corners	2
	880X	AX00.090.880.A.SP	3/8 x 3 1/2 Flat slotted concrete sleeve anchor (QTY 2)	U Channel 90 degree corners	2
	885X	AX00.090.885.A.SP	3/8 x 3 1/2 Flat head wood screw (QTY 10)	U Channel floor and wall mount (2500mm)	10
	890X	AX00.090.890.A.SP	3/8 x 3 1/2 Flat slotted concrete sleeve anchor (QTY 10)	U Channel floor and wall mount (2500mm)	10
	895X	AX00.090.895.A.SP	3/8 x 3 1/2 Flat head wood Screw (QTY 20)	U Channel floor and wall mount (5000mm)	20
	899X	AX00.090.899.A.SP	3/8 x 3 1/2 Flat slotted concrete sleeve anchor (QTY 20)	U Channel floor and wall mount (5000mm)	20
	900X	AX00.090.900.A.SP	M6 x 80 Wood screw with socket head (QTY 2)	Standoffs / side mount post brackets	2
	905X	AX00.090.905.A.SP	M6 x 80 Machine screw with socket head (QTY 2)	Standoffs / side mount post brackets	2

COD.

**AX00.100.563**

PERMABOND MH052 is ideal for the sealing of threaded joints. It is approved for use with gas for working pressure up to 26 bar and also for gaseous oxygen up to 10 bar and 60°C. MH052 seals against gas, water, LPG, hydrocarbons, oils and other chemicals. Unlike PTFE tape or hemp, Permabond MH052 will not shred or dry out, so it will provide a durable seal, helping to extend the life of the components. 75 ml

**Thread Lock**

**Weight:** .18 kgs (.4 lbs)



COD.

**AX00.100.525**

PERMABOND HM162 is a medium viscosity retaining compound that cures when confined between metal parts to form an extremely tough bond. It is best suited for cylindrical parts and where high temperature resistance is required. In the uncured, liquid state, the adhesive wets the metal surfaces, keying into all surface irregularities and fills the space between the mated parts. 50 ml

**Sealant Adhesive**

**Weight:** .136 kgs (.3 lbs)

COD.

**EPC-410**

Epoxy Adhesive, Rapid Cure, High Strength Paste, Translucent, 50mL, Cartridge, Mixing Ratio 1:1, Application Time 7 min., Functional Cure 4 Hrs, Full Cure 4 hr., Work Life 15 min., Substrates Metal, Wood, Brick, Stone, Marble, Rubber, Some Plastics, And More, Repairing and Bonding For Home, Farm, Office and Marine Automotive, Includes 2 Nozzles, Package Quantity 1

**Two part epoxy**

**Weight:** .114 kgs (.25 lbs)



COD.

**EPC-101**

Simultaneously mix and dispense 2-part adhesives. Holds 50 ml cartridges.

**Epoxy gun**

**Weight:** .179 kgs (.394 lbs)



COD.

**S-2611**

Titebond® 100% Silicone Sealant is a versatile formula that is ideal for both interior and exterior applications. It is a RTV industrial sealant and offers excellent adhesion to many common construction materials, including vinyl, aluminum, glass and painted surfaces. It also provides a strong, flexible seal that offers excellent water-resistance.

When fully cured, Titebond 100% Silicone Sealant can withstand extreme temperature conditions. The 100% antimicrobial formula will not crack or become brittle with age and resists fading or yellowing. It also extrudes easily in lower temperatures and dries quickly.

**Clear Silicone Sealant**

**Weight:** .365 kgs (.803 lbs)



COD.

**AX00.080.505**

- Superior alternative to steel wool, wire brushes, sandpaper, and other non-woven products for cleaning or finishing tasks.
  - Very fine grade aluminum oxide abrasive cleans, finishes, grains, denibs, and defuzzes.
  - Pad resists tearing, splintering, shredding, loading and will never rust, providing a long, useful life.
  - Can be folded, stacked, or rolled for effective cleaning or conditioning on flat, irregular, or contoured surfaces.
- Package of 2

**Scotch Brite Pads**

**Weight:** .116 kgs (.256 lbs)

COD.

**AX00.080.515**

Our strongest cleaner, ideal for removing hard to clean substances from all stainless steel products. Used most commonly after installation and prior to applying polish and passivator.

**Degreaser**

**Weight:** 108 kgs (.238 lbs)



COD.

**AX00.080.510**

Ideal for normal cleaning and maintenance of all stainless steel products. Use prior to applying passivator.

**Cleaner/Polish**

**Weight:** 108 kgs (.238 lbs)















COD.

**AX00.080.517**

Essential for maximum corrosion resistance of all stainless steel products. Use after applying degreaser and polish.

**Polish/Passivator**

**Weight:** 108 kgs (.238 lbs)

<p>COD.</p> <p><b>AX00.070.640</b>     <b>212 Metal Post Drill Kit</b></p> <p><b>Includes:</b> 5/32" Metal drill bit 29/64" Metal drill bit 3/16" Open end wrench</p> <p><b>Weight:</b> .073 kgs (.16 lbs)</p>		<p>COD.</p> <p><b>AX00.070.620</b>     <b>262 Wood Post Drill Kit</b></p> <p><b>Includes:</b> 5/32" Wood drill bit 29/64" Wood drill bit 1/4" Wood drill bit 3/16" Allen wrench</p> <p><b>Weight:</b> .082 kgs (.18 lbs)</p>	
<p>COD.</p> <p><b>AX00.070.635</b>     <b>102 Metal Post Drill Kit</b></p> <p><b>Includes:</b> 29/64" Metal drill bit 1/4" Metal drill bit 7/16" Open end wrench</p> <p><b>Weight:</b> .073 kgs (.16 lbs)</p>		<p>COD.</p> <p><b>AX00.070.630</b>     <b>102 Wood Post Drill Kit</b></p> <p><b>Includes:</b> 29/64" Wood drill bit 1/4" Wood drill bit 7/16" Open end wrench</p> <p><b>Weight:</b> .073 kgs (.16 lbs)</p>	
<p>COD.</p> <p><b>AX00.070.645</b>     <b>401 Metal Post Drill Kit</b></p> <p><b>Includes:</b> 5/32" Metal drill bit 3/8" Open end wrench</p> <p><b>Weight:</b> .082 kgs (.18 lbs)</p>		<p>COD.</p> <p><b>AX00.070.627</b>     <b>601 Wood Post Drill Kit</b></p> <p><b>Includes:</b> 5/32" Wood drill bit 9/32" Wood drill bit 29/64" Wood drill bit 1/4" Wood drill bit 3/16" Allen wrench</p> <p><b>Weight:</b> .091 kgs (.2 lbs)</p>	
<p>COD.</p> <p><b>AX00.070.650</b>     <b>500M Metal Post Drill Kit</b></p> <p><b>Includes:</b> 5/32" Metal drill bit 3/8" Open end wrench</p> <p><b>Weight:</b> .073 kgs (.16 lbs)</p>		<p>COD.</p> <p><b>AX00.070.625</b>     <b>300,500 Wood Post Drill Kit</b></p> <p><b>Includes:</b> 5/32" Wood drill bit 7/32" Wood drill bit 3/8" Open end wrench</p> <p><b>Weight:</b> .068 kgs (.15 lbs)</p>	
<p>COD.</p> <p><b>AX00.070.610</b>     <b>Bulk Cable &amp; Fittings Drill Bit</b></p> <p><b>Includes:</b> 5/16" Kobalt drill bit</p> <p><b>Weight:</b> .023 kgs (.05 lbs)</p>		<p>COD.</p> <p><b>AX00.070.605</b>     M5mm drill &amp; tap set (handrail) <b>AX00.070.606</b>     M6mm drill &amp; tap set (bar holders) <b>AX00.070.608</b>     M8mm drill &amp; tap set (glass clamps)</p> <p><b>Drill &amp; tap set</b></p> <p><b>Weight:</b> .045 kgs (.1 lbs)</p>	
<p>COD.</p> <p><b>AX00.070.651</b>     3/8" punch for precision drilling.</p> <p><b>Center punch</b></p> <p><b>Weight:</b> .068 kgs (.15 lbs)</p>		<p>COD.</p> <p><b>S-9403</b>     Sure tite fastener for wood newel posts. <b>Sure Tite Newel Fastener</b></p> <p><b>Weight:</b> .249 kgs (.55 lbs)</p> <p><b>S-9401</b>     Key lock fastener for wood newel posts. <b>Key Lock Newel Fastener</b></p> <p><b>Weight:</b> .301 kgs (.66 lbs)</p>	
<p>COD.</p> <p><b>AX00.070.652</b>     Tap Magic Pro Tap 16 oz spout top.</p> <p><b>Cutting fluid</b></p> <p><b>Weight:</b> .454 kgs (1 lbs)</p>		<p><b>AX00.110.710</b>     Composite shims for proper post leveling/mounting.</p> <p><b>Shims (12 pack)</b></p> <p><b>Weight:</b> .331 kgs (.73 lbs)</p>	



COD.

**HFC18.C9CUTTER**

Ideal for cutting our stainless steel cable or any cable up to 1/4" thickness.

**Cable cutter - large**

**Weight:**  
.86 kgs (1.89 lbs)



COD.

**HFC18.CUTTER**

Ideal for cutting our stainless steel cable or any cable up to 1/8" thickness

**Cable cutter - small**

**Weight:**  
.344 kgs (.74 lbs)



COD.

**HFC18.WHEEL**

Make close cuts on cable with clean finished ends.

**Cable cut-off wheel**

**Weight:**  
.085 kgs (.187 lbs)



COD.

**HFC18.PLIER**

Cable gripping pliers for proper tensioning.

**Cable gripping pliers**

**Weight:**  
.748 kgs (1.65 lbs)



COD.

**HFC18.TENSION.GAUGE**

Accurately measure tension on cable railing.

**Tension Gauge**

**Weight:**  
.241 kgs (.53 lbs)



COD.

**HFC18.TUBE**

Insert tube for use with 1/8" cable and wood posts.

**Insert Tube**

**Weight:**  
.005 kgs (.01 lbs)



COD.

**HFC18.KEY**

Release key for all push lock fitting cable kits.

**Cable Release Key**

**Weight:**  
.005 kgs (.01lbs)



COD.

**HFC18.DRIVER**

Hanger bolt driver for use with our HFC18.500 cable kit

**Hanger bolt driver**

**Weight:**  
.204 kgs (.45 lbs)



COD.

**AX00.060.550**

Allen wrench for use with our middle tensioning body (AX00.050.235.B.SP).

**Allen wrench**

**Weight:**  
.005 kgs (.01lbs)





COD.

**AX10.070.212**

Accurately bend 12 mm round infill tubing for curved applications.

**Infill tube bender**

**Weight:**  
.301 kgs (6.35 lbs)

COD.

**AX00.060.400**

Our two stage hydraulic swaging compression tool allows for up to 16 tons of pressure to be applied to cable fittings. Full die set included for 3, 4, 5, 6 mm .

**Hydraulic Crimper**

**Weight:**  
4.2 kgs (9.25 lbs)



COD.

**AX00.060.415**

**AX00.060.420**

Die set for 3/4mm  
Die set for 5/6mm

**Die set**

**Weight:**  
.045 kgs (.1 lbs)

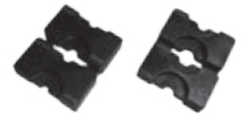

COD.

**AX00.070.520**

Threaded pop rivet installation gun. Interchangeable mandrel/nosepieces for blind rivet nuts sizes: M3,M4,M5,M6,M8

**Pop rivet gun**

**Weight:**  
2.52 kgs (5.55 lbs)



COD.

**AX30.070.530**

Spanner wrench for tightening round standoffs.

**Spanner wrench - round**

**Weight:**  
.187 kgs (.412 lbs)



COD.

**AX30.070.531**

Spanner wrench for tightening square standoffs.

**Spanner wrench - square**

**Weight:**  
.295 kgs (.65 lbs)



COD.

**AX40.070.562**

This multi-function tool allows you to precisely hammer wedges into place and roll the rubber strip into place on U channel.

**Wedge tool**

**Weight:**  
.68 kgs (1.5 lbs)





© 2017 AXIA STAIR & RAILING SYSTEMS  
All images are copyrighted and cannot be reproduced without expressed  
written consent. Unauthorized use is prohibited and punishable by law.

[www.axiarailing.com](http://www.axiarailing.com)

Full Product Line Catalog Edition 001-A



YOUR STAIR & RAILING CO.

**Houston** 16684 Air Center Blvd. Houston, Texas 77032  
Phone 281.209.0000 Fax 281.209.0067

**Austin** 8606 Wall St. Suite 200 Austin, Texas  
Phone 512.973.8373 Fax 512.973.9919

**San Antonio** Phone 210.521.4808 Fax 210.521.7618

**Dallas** 2520 N Great Southwest Pkwy. Suite 104  
Grand Prairie, Texas 75050  
Phone 817.701.2006 Fax 817.701.2020

[www.ironwoodusa.com](http://www.ironwoodusa.com)

**AXIA**<sup>®</sup>  
STAIR & RAILING SYSTEMS